

UV Combustion Safeguard With Fire Eye

Power Block
120 v.-1 Ph.-60 Hz.

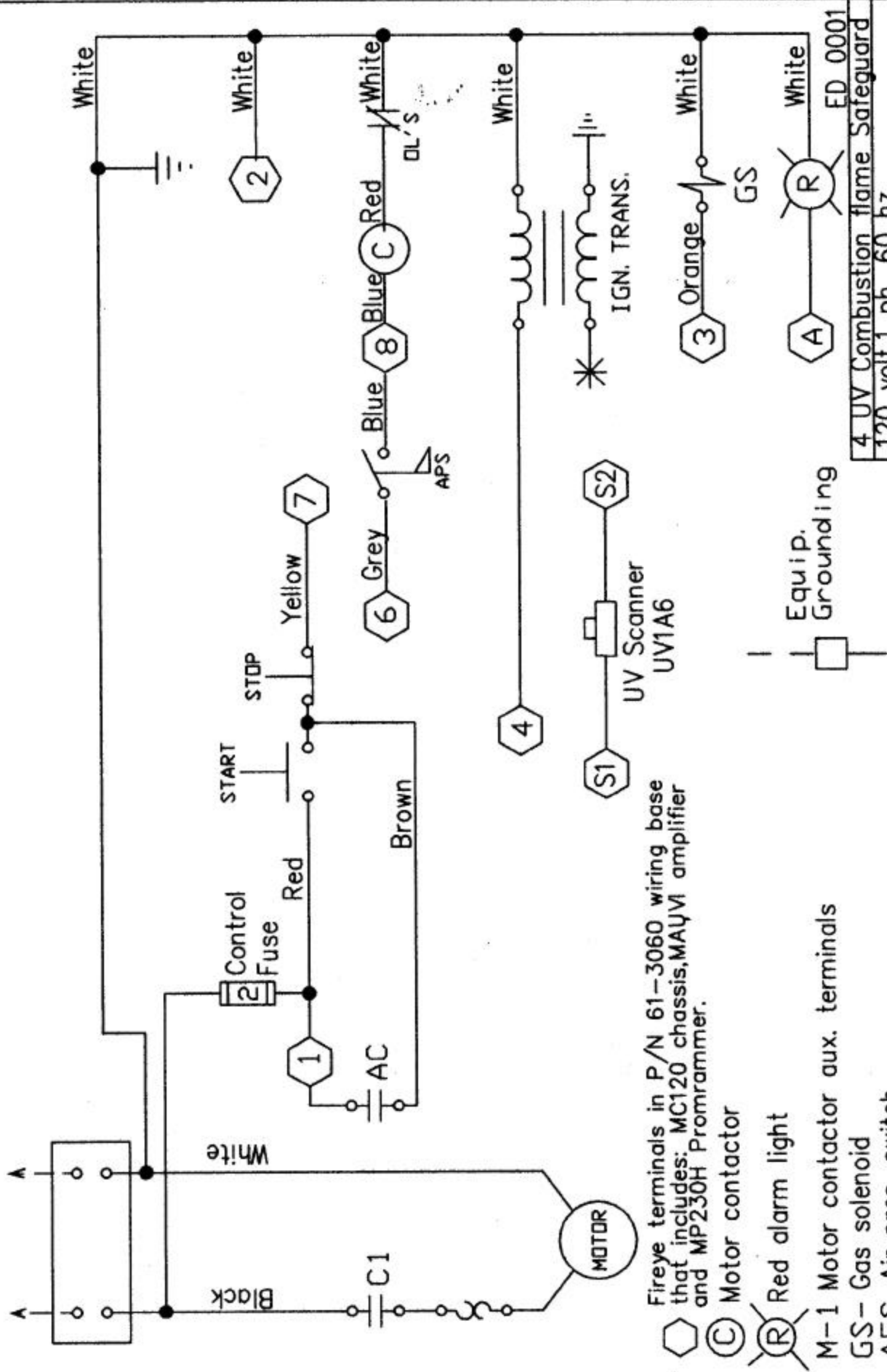

Fireye terminals in P/N 61-3060 wiring base that includes: MC120 chassis, MAUVI amplifier and MP230H Promammer.

- (C) Motor contactor
- (R) Red alarm light
- M-1 Motor contactor aux. terminals
- GS- Gas solenoid
- AFS-Air pres. switch
- DLS-Motor overloads



| | |
|---------------------------------|-----------|
| 4 UV Combustion flame Safeguard | ED 0001 |
| 120 volt, 1 ph, 60 Hz. | |
| MITFCO | 9/22/1999 |

UV Combustion Safeguard With Fire Eye

Power Block 220 V, 1 Ph., 60 Hz.

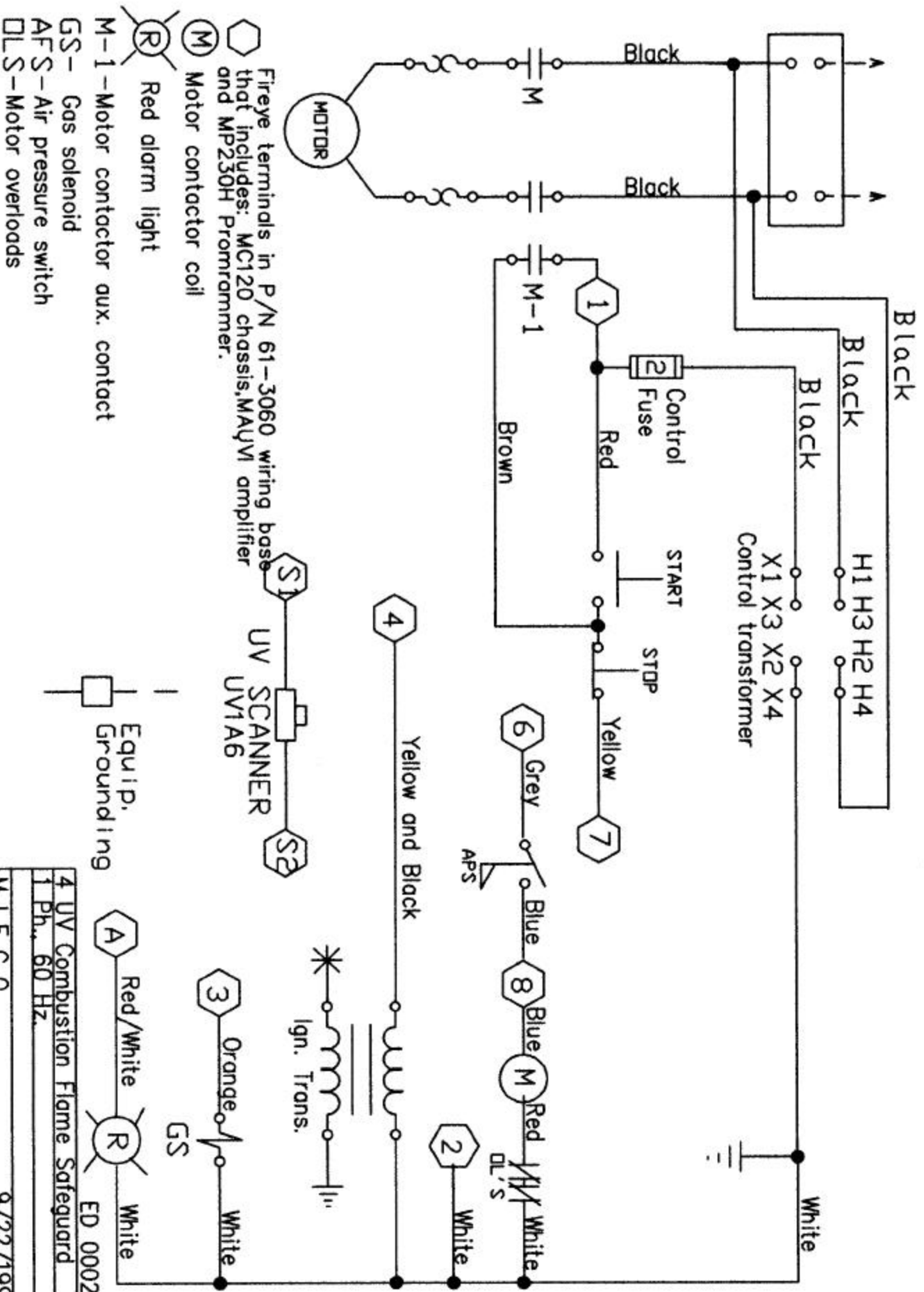

Fireeye terminals in P/N 61-3060 wiring base that includes: MC120 chassis, MAQVI amplifier and MP230H Promammer.

- (M) Motor contactor coil
- (R) Red alarm light
- M-1 - Motor contactor aux. contact
- GS - Gas solenoid
- AFS - Air pressure switch
- DL'S - Motor overloads

Equip. Grounding

| | |
|-----------|-------------------------------|
| 4 | UV Combustion Flame Safeguard |
| 1 | Ph., 60 Hz. |
| M I F C O | |
| 9/22/1999 | |

UV Combustion Safeguard With Fire Eye

Power Block
230 V, 3 Ph., 60 Hz.

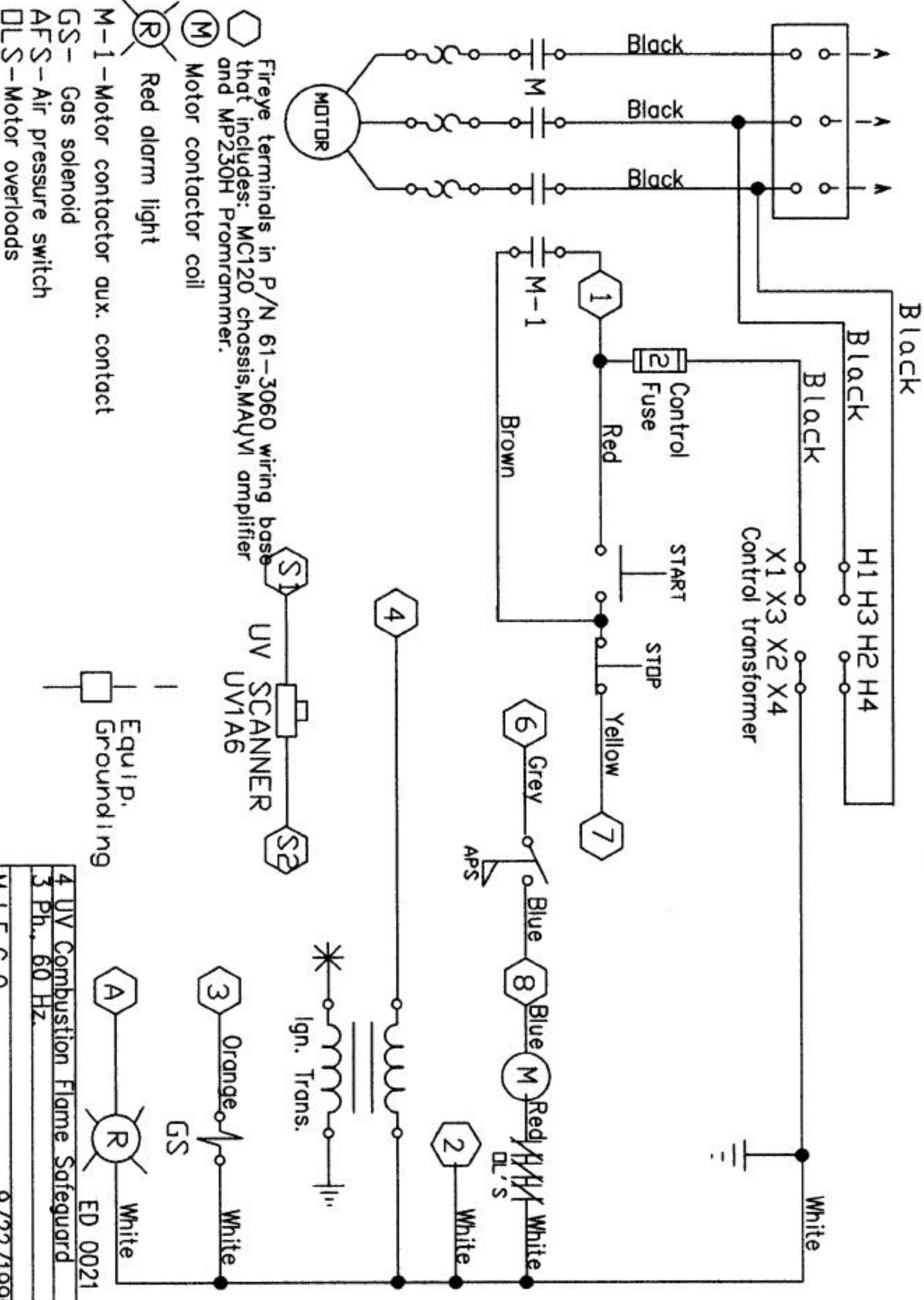

Fireye terminals in P/N 61-3060 wiring base that includes: MC120 chassis, MAYVI amplifier and MP230H Promammer.

- (M) Motor contactor coil
- (R) Red alarm light
- M-1 - Motor contactor aux. contact
- GS - Gas solenoid
- AFS - Air pressure switch
- DL'S - Motor overloads

Equip. Grounding

| | |
|-----------|-------------------------------|
| 4 | UV Combustion Flame Safeguard |
| 3 | Ph., 60 Hz. |
| M I F C O | |
| 9/22/1999 | |

ED 0021

Power Block UV Combustion Safeguard 460 V, 3 Ph., 60 Hz. With Fire Eye

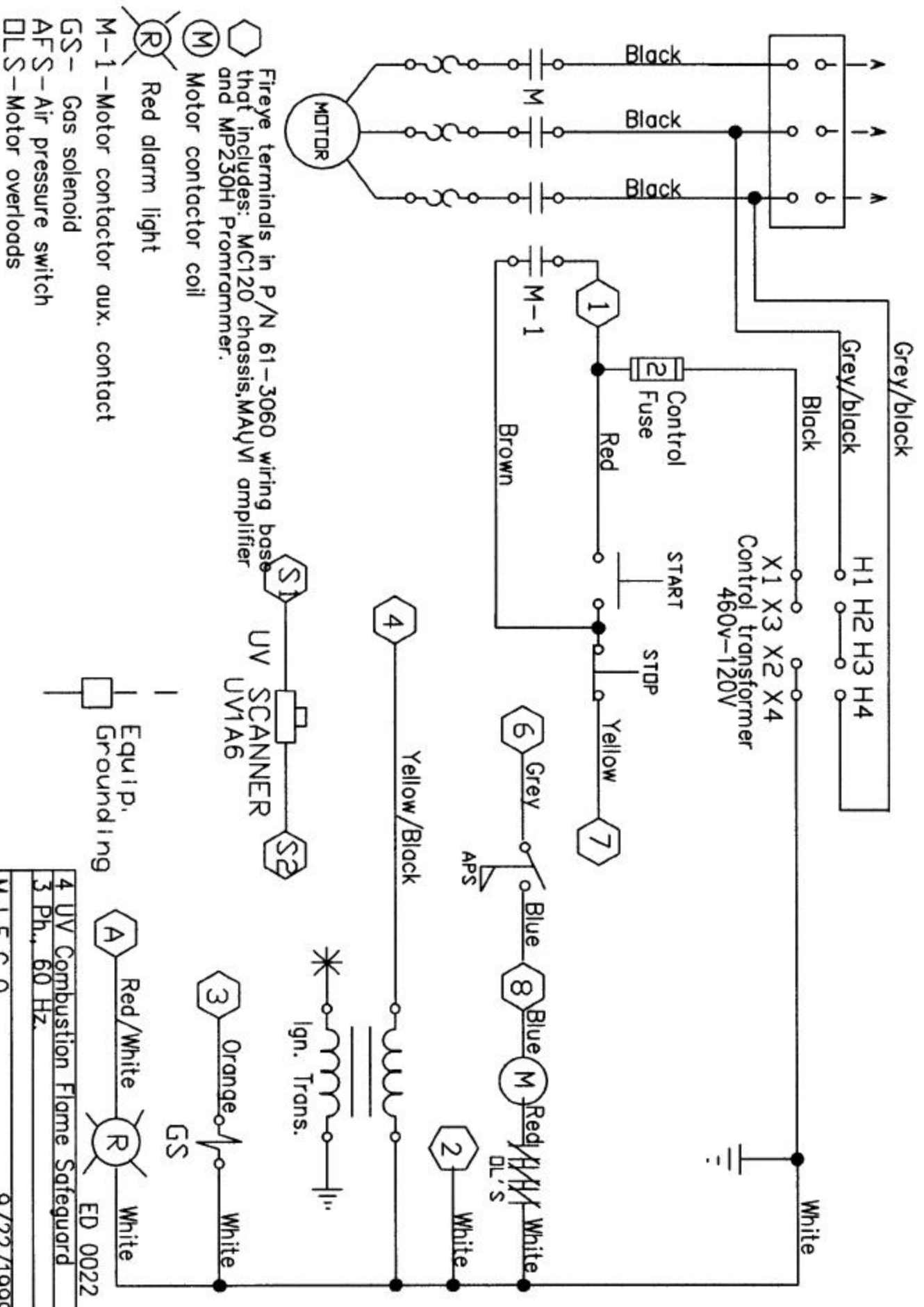

Fire eye terminals in P/N 61-3060 wiring base that includes: MC120 chassis, MAYVI amplifier and MP230H Promrammer.

- (M) Motor contactor coil
- (R) Red alarm light
- M-1 - Motor contactor aux. contact
- GS - Gas solenoid
- AFS - Air pressure switch
- DLS - Motor overloads

| | |
|---------------|-------------------------------|
| 4 | UV Combustion Flame Safeguard |
| 3 Ph., 60 Hz. | |
| M I F C O | |
| 9/22/1999 | |

ED 0022

UV Combustion Safeguard With Fire Eye

Power Block
120 v.-1 Ph.-60 Hz.

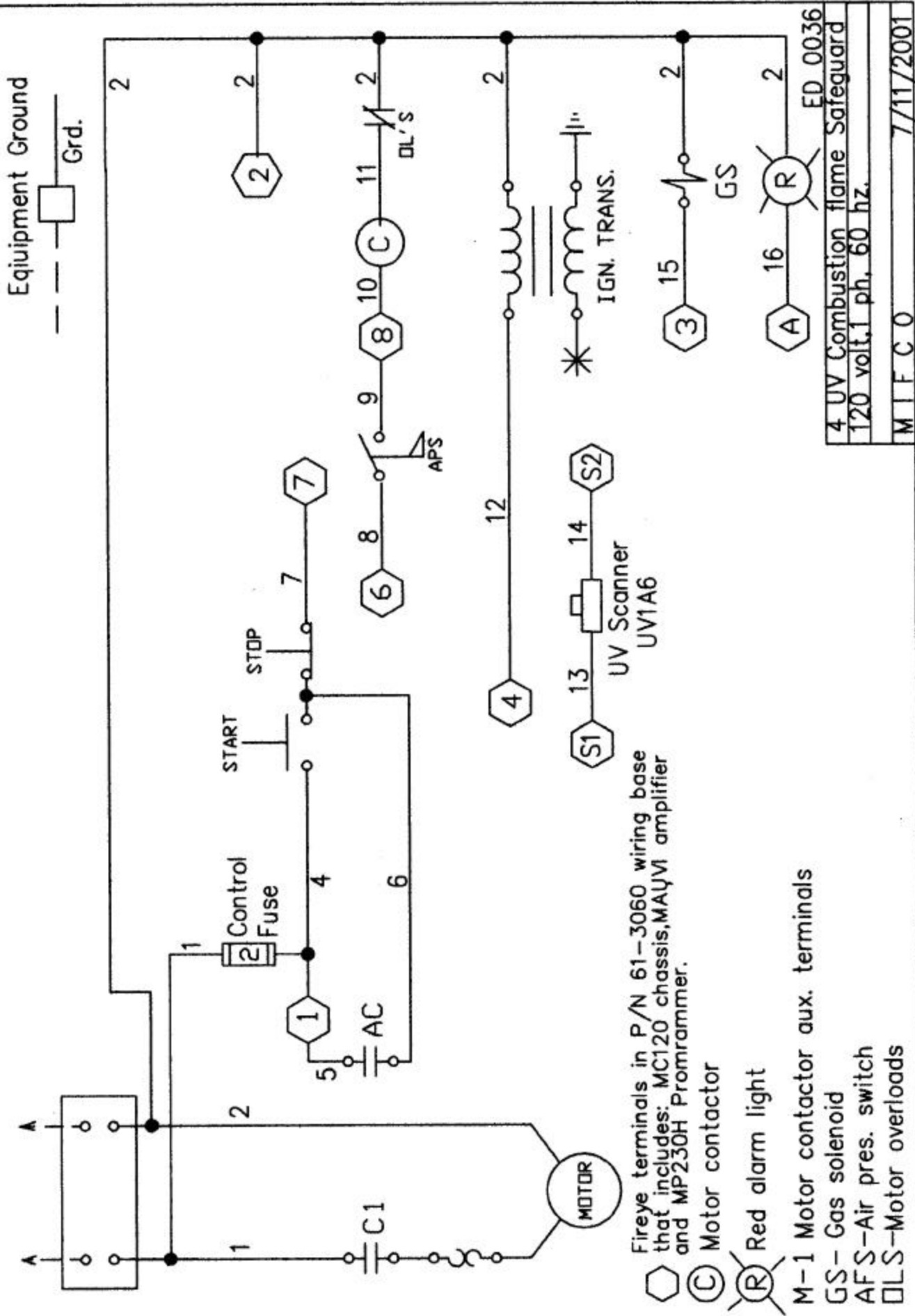

Fireye terminals in P/N 61-3060 wiring base that includes: MC120 chassis, MAUVI amplifier and MP230H Programmer.

Motor contactor

Red alarm light

M-1 Motor contactor aux. terminals

GS - Gas solenoid

AFS - Air pres. switch

DL'S - Motor overloads

UV Combustion Safeguard With Fire Eye--Canadian System

Power Block

220 V, 1 Ph., 60 Hz.

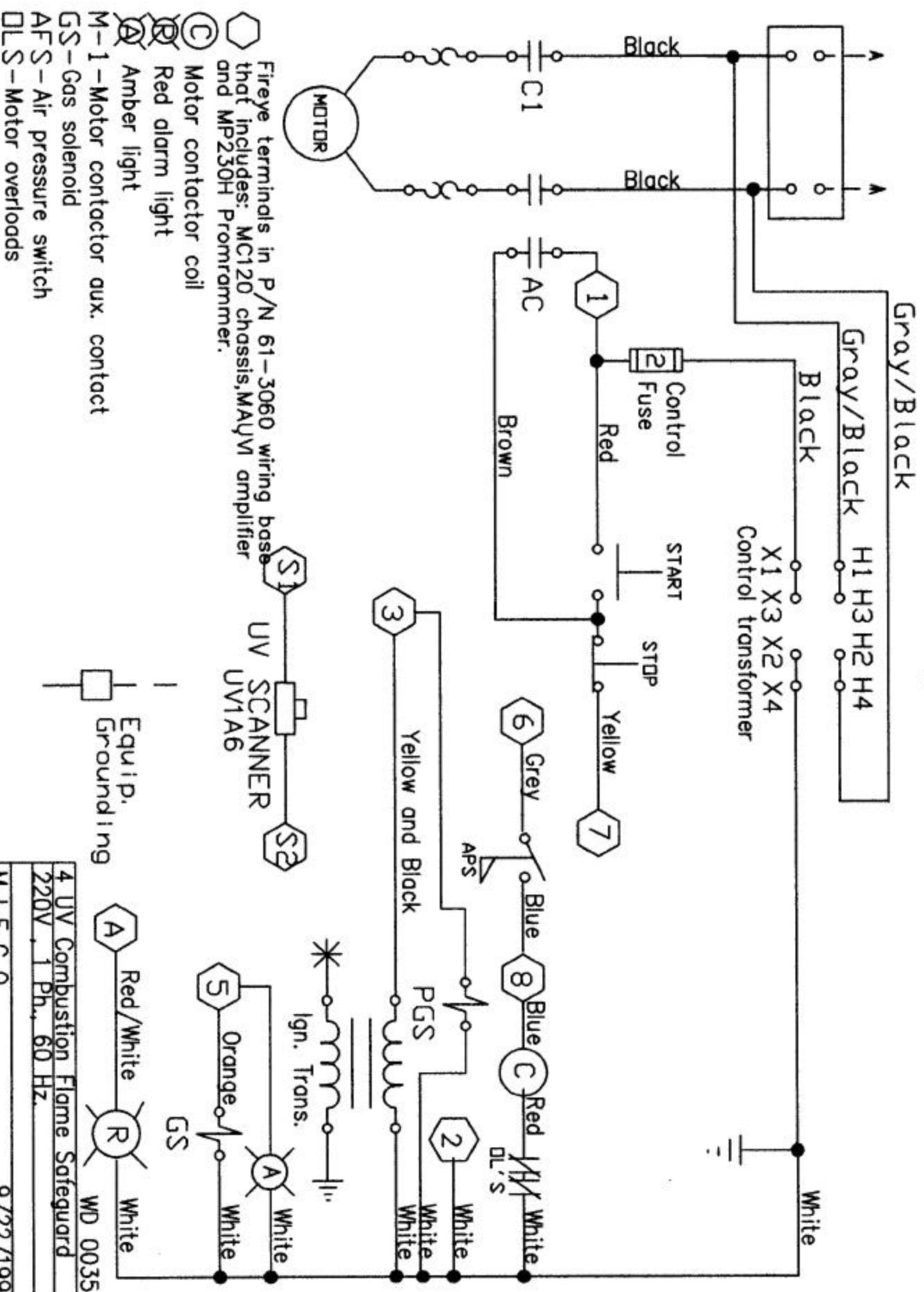

Fireeye terminals in P/N 61-3060 wiring base that includes: MC120 chassis, MA4V1 amplifier and MP230H Promrammer.

- (C) Motor contactor coil
- (R) Red alarm light
- (A) Amber light
- M-1 - Motor contactor aux. contact
- GS - Gas solenoid
- AFS - Air pressure switch
- OLS - Motor overloads

| | |
|-----------|-------------------------------|
| 4 | UV Combustion Flame Safeguard |
| 220V | 1 Ph., 60 Hz. |
| M I F C O | |
| 9/22/1999 | |

Power Supply
120V 1Ph 60Hz

UV Combustion Safeguard With Honeywell RM 7895 B

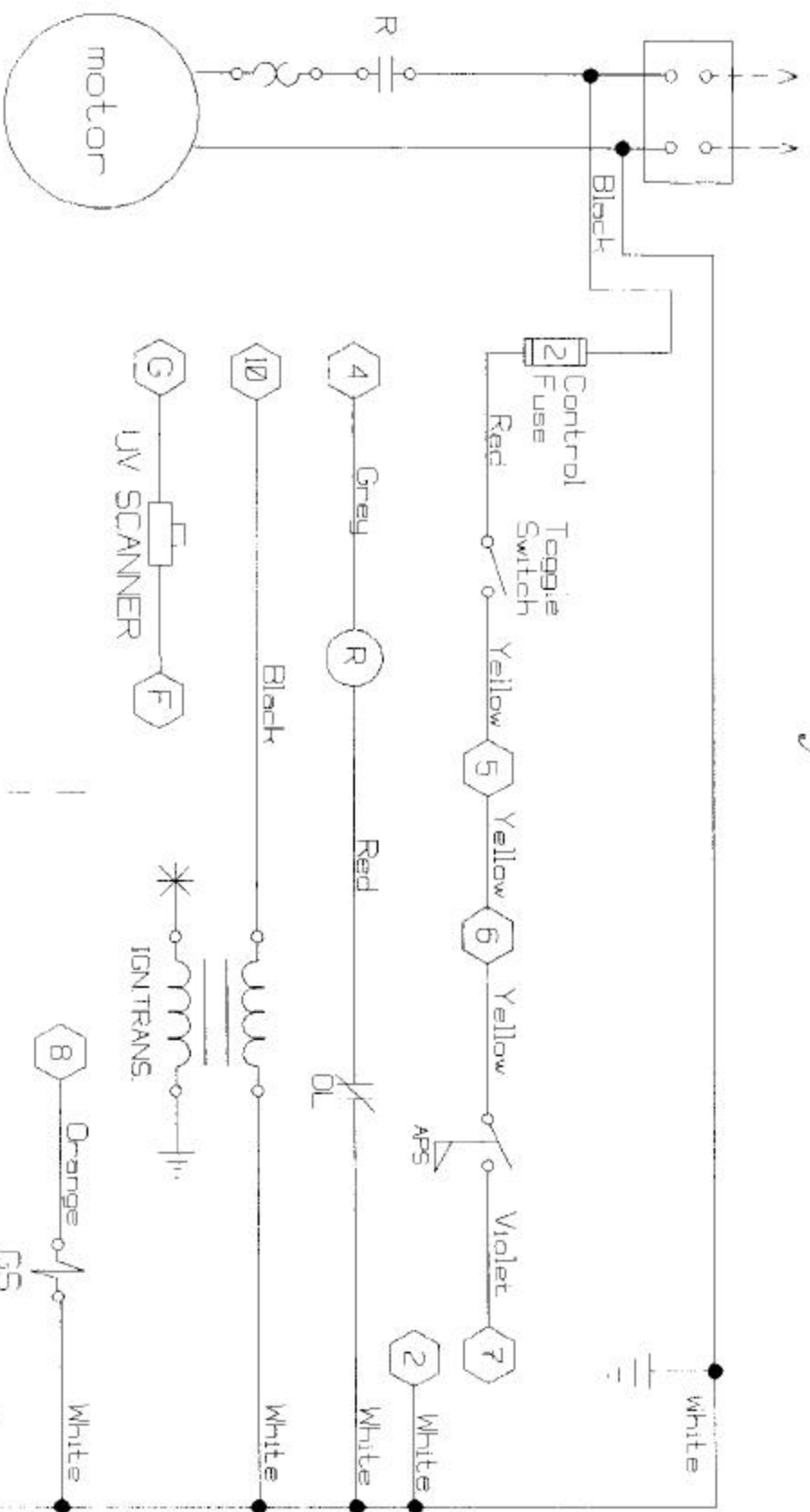

- (R) APS: Air Pressure Switch
- GS: Gas Solenoid
- DL-1: Motor Overload
- (R) Motor: Contactor Coil

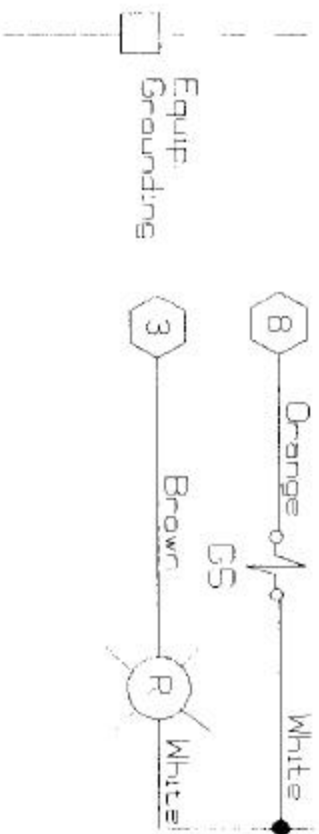

5/13/94

MFI TFRS\F100015

Power Supply
220V 1Ph 60 Hz

UV Combustion Safeguard With Honeywell RM 7895 B

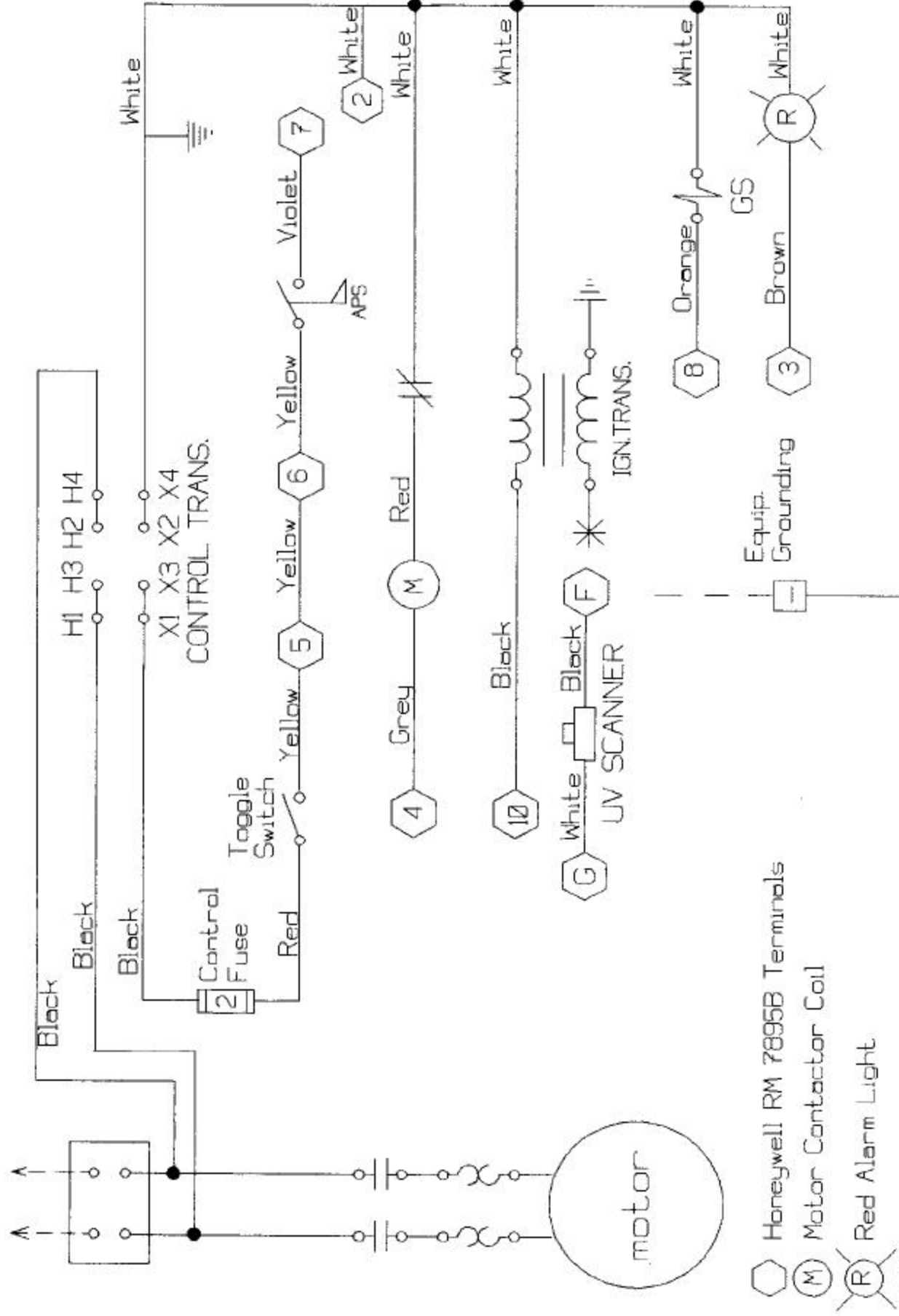

- Honeywell RM 7895B Terminals
- (M) Motor Contactor Coil
- (R) Red Alarm Light
- △ APS-Air Pressure Switch
- GS - Gas Solenoid

Power Supply
 230V 3PH 60Hz

UV Combustion Safeguard With Honeywell RM 7895 B

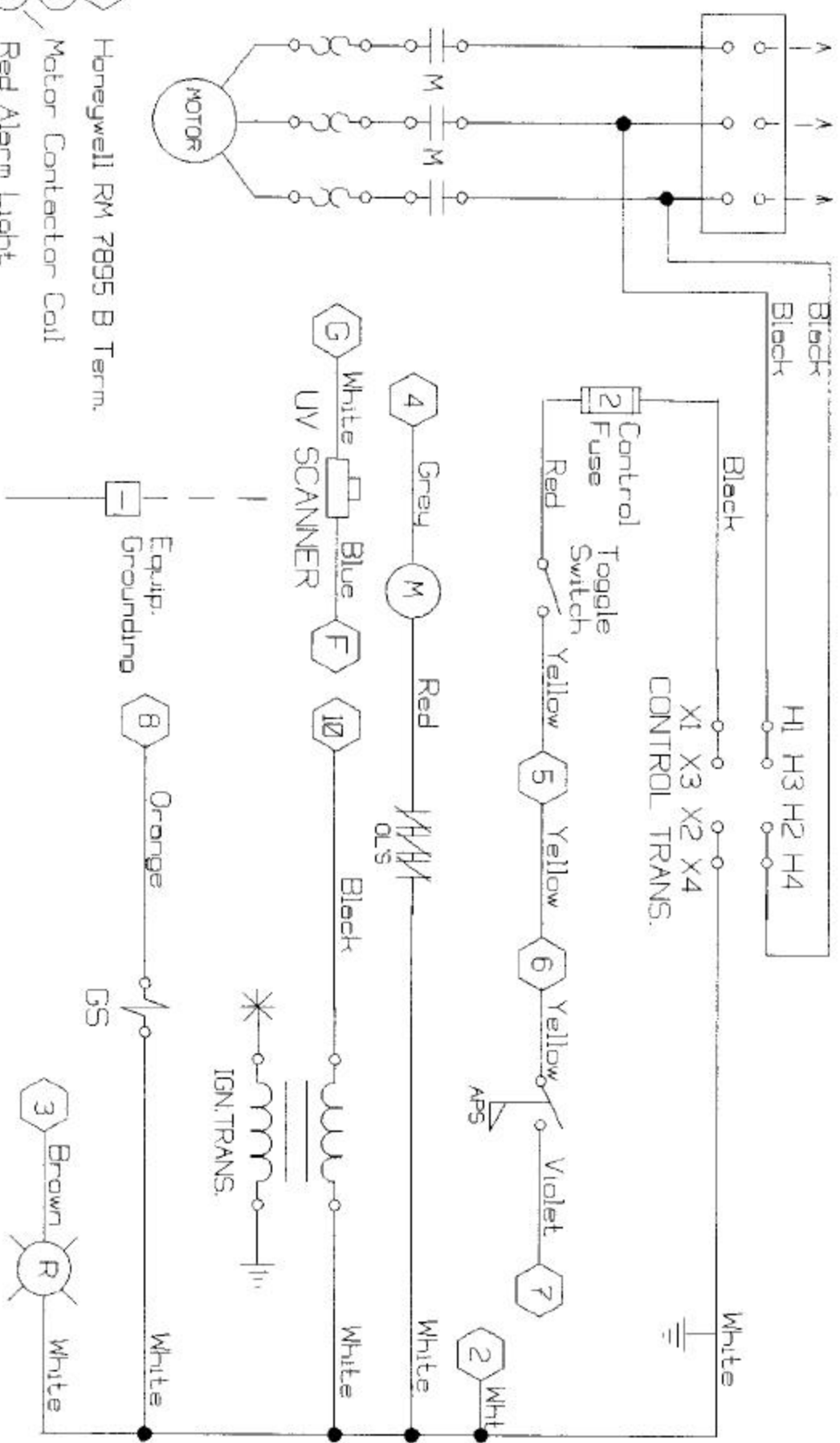

- Honeywell RM 7895 B Term.
- Motor Contactor Coil
- Red Alarm Light
- OLS Motor Overloads
- Gas Solenoid Valve
- Motor Contactor

5/13/94

MELTERS\ED0007

4UV Combustion Safeguard With Fire Eye

Equipment Ground.
- - - - -

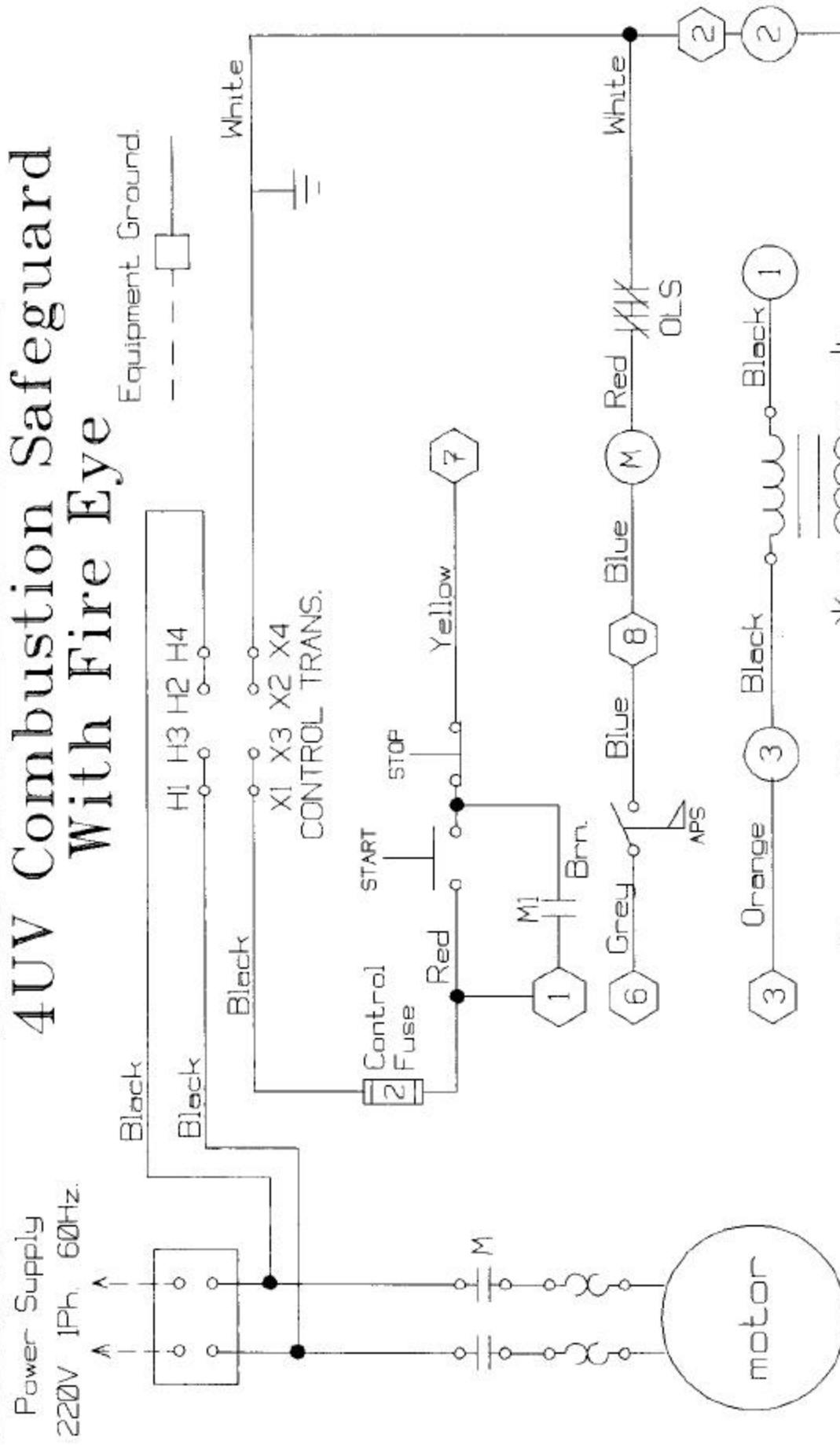

- ⬡ UV Fire Eye Cont. Term.
- ⬡ APS- Air Pressure Switch
- ⬡ GS- Gas Solenoid
- ⬡ OLS- Motor Overloads
- (M) Motor Contactor Coil
- (R) Red Alarm Light

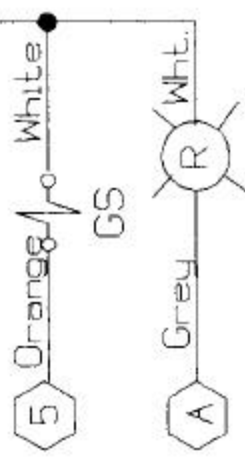

Power Block

230 V. 3 PH. 60 Hz.

UV Combustion Safeguard With Fire Eye

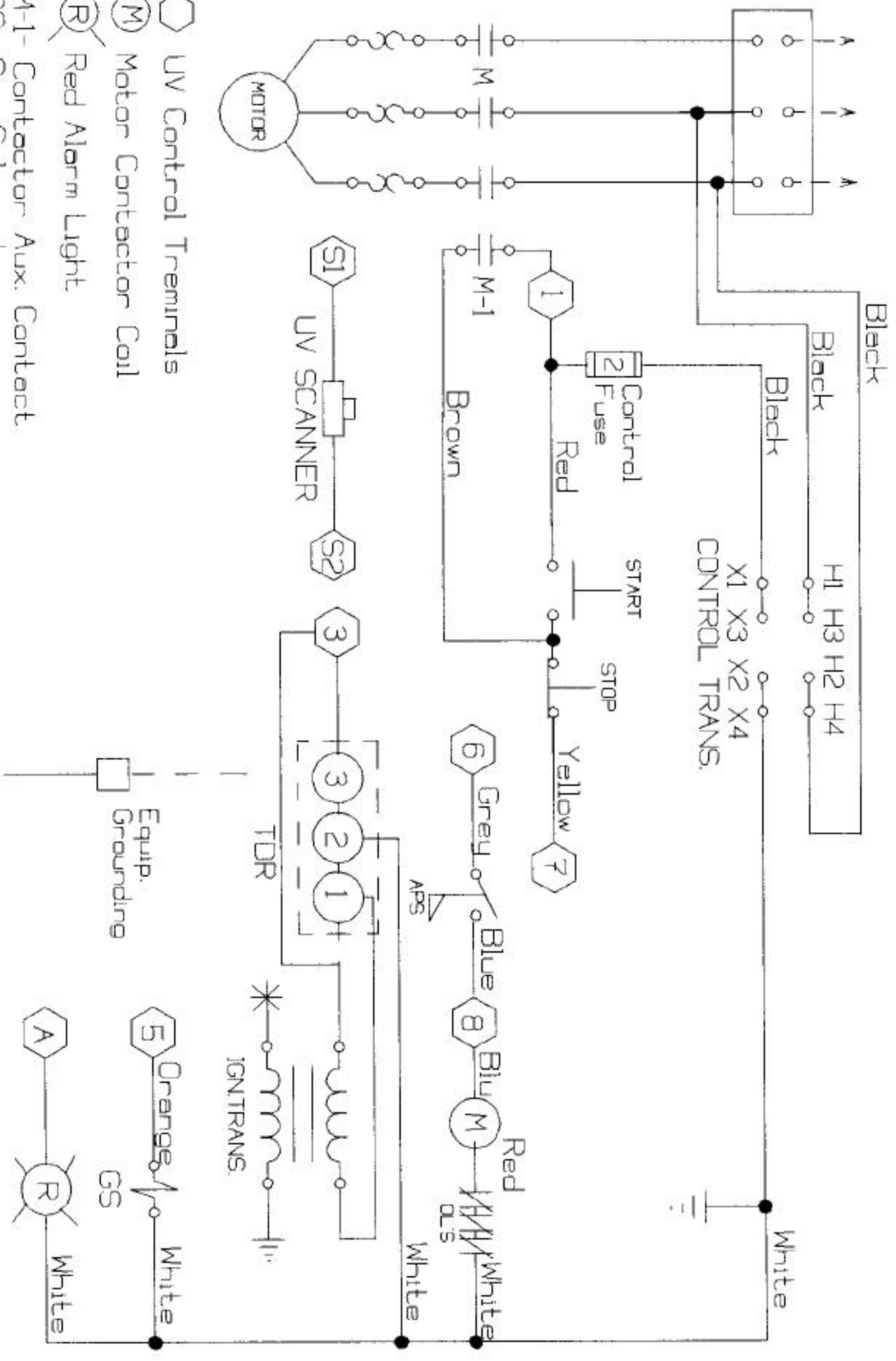

- ⬡ UV Control Terminals
- Ⓜ Motor Contactor Coil
- Ⓡ Red Alarm Light
- M-1- Contactor Aux. Contact
- GS- Gas Solenoid
- AFS- Air Pres. Switch
- O/S- Motor Overloads

UV Combustion Safeguard With Fire Eye

Power Supply
460V. 3Ph. 60Hz.

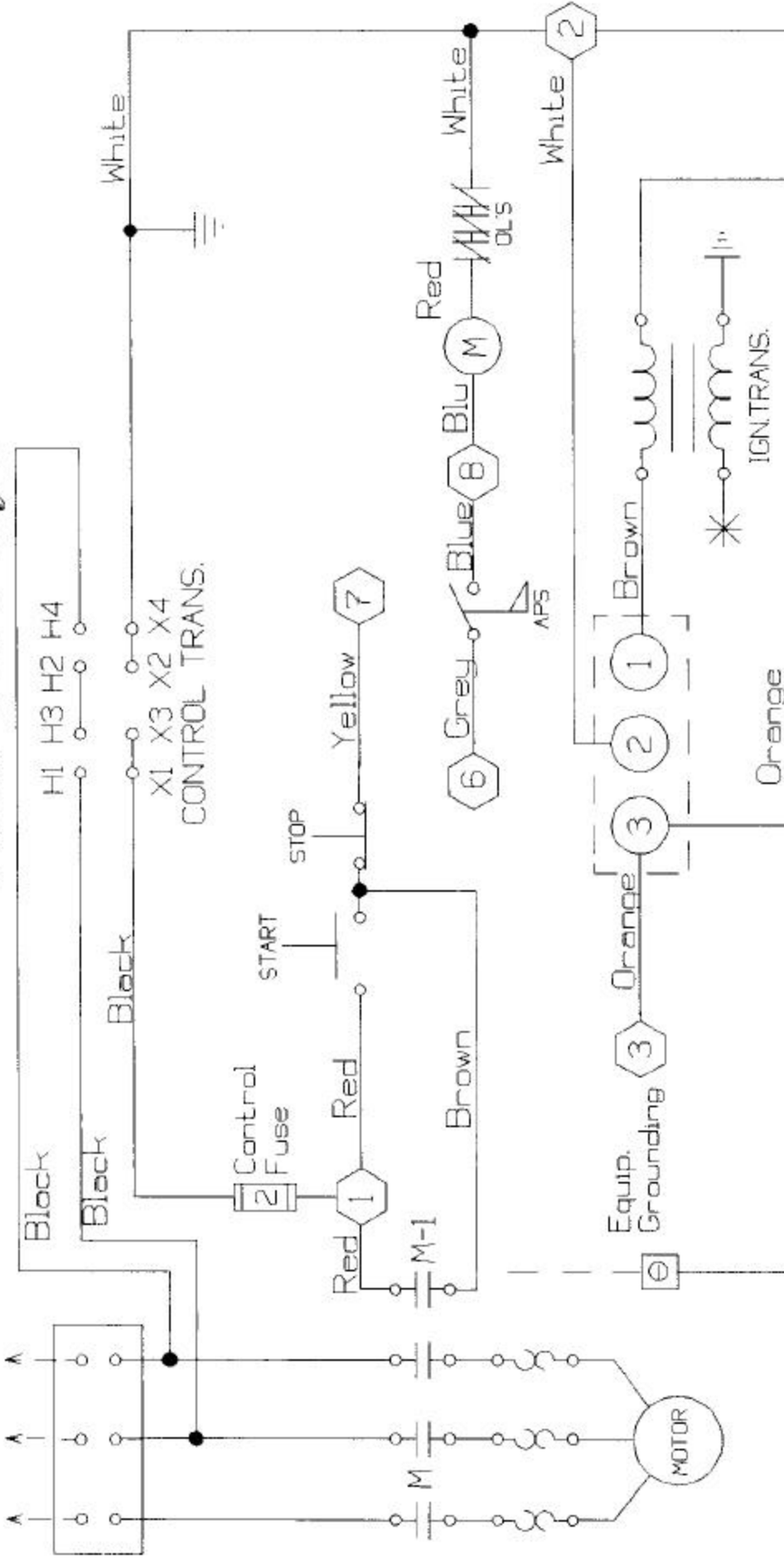

- UV Control Terminals
- Motor Contactor Coil
- Red Alarm Light

- M-1 - Contactor Aux. Contact
- GS - Gas Solenoid
- AFS - Air Pressure Switch
- OLS - Motor Overloads

