

PART NAME  
DRAWING NUMBER  
DATE  
REVISION DATE  
QUANTITY PER UNIT  
MATERIAL  
DIMENSION

FUSED POWER SUPPLY  
230 V / 3 PH / 60 HZ

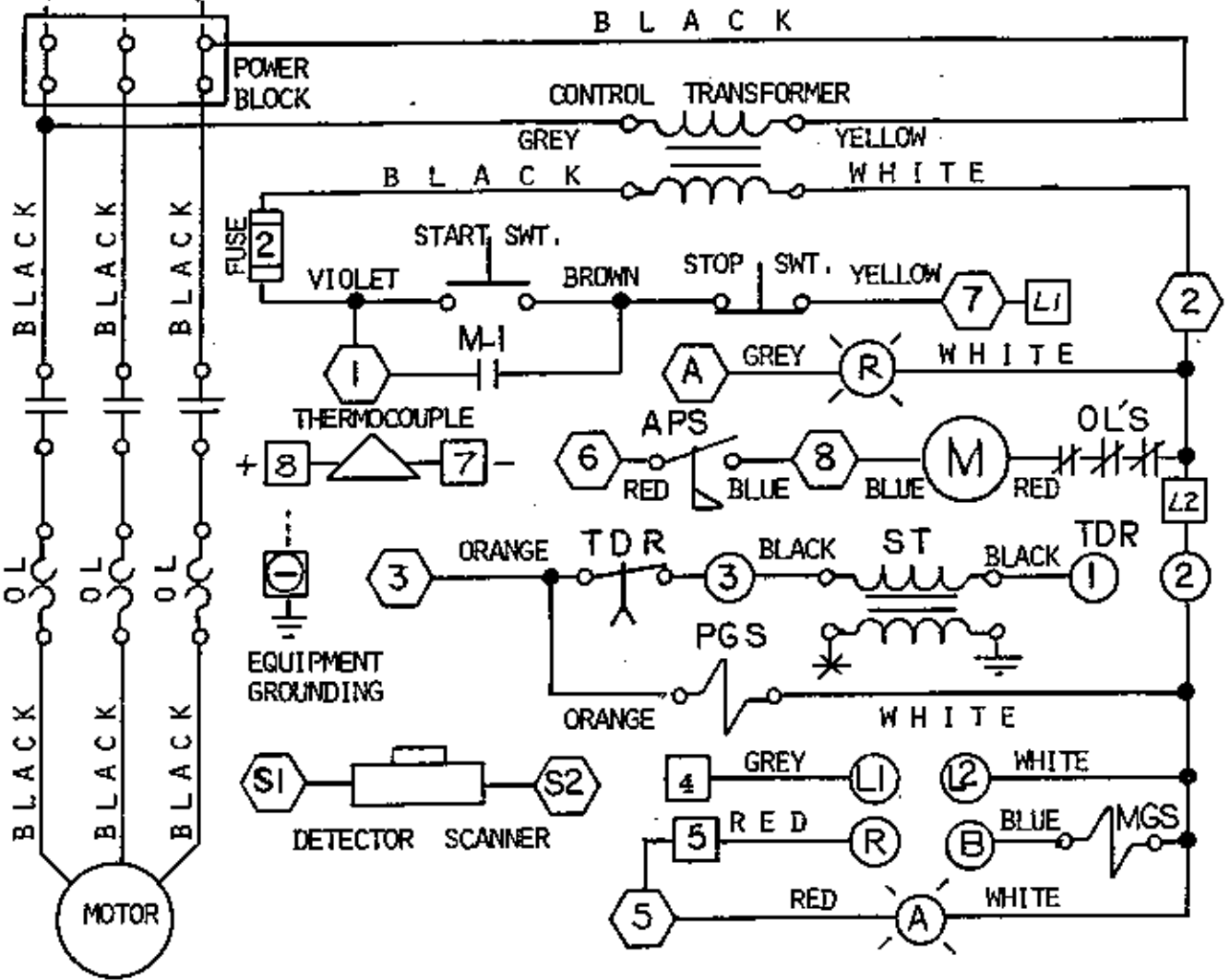

COMBUSTION SAFEGUARD SYSTEM 6UV

LEGEND

- TEMPERATURE CONTROL TERMINALS
- ULTRA VIOLET CONTROL TERMINALS
- TIME DELAY CONTROL TERMINALS
- CONTROL LIGHTS
- ST SPARK TRANSFORMER
- PGS PILOT GAS SOLENOID VALVE
- OL'S MOTOR OVERLOAD RELAYS
- M MOTOR MAGNETIC STARTER
- M I STARTER CONTACTS
- MGS MAIN GAS SOLENOID VALVE
- APS AIR PRESSURE SWITCH

NOTE

- I THE WIRE SELECTION WERE BASED ON CONDUCTORS FOR HIGH TEMPERATURE RATING PER N.E.C. TABLE 312-12
- II FIELD MUST PROVIDE GROUNDED POWER SUPPLY PER O.S.H.A. REQUIREMENTS.
- III IN CASE OF POWER FAILURE THE SAFETY SYSTEM WILL AUTOMATICALLY SHUT DOWN AND WILL NOT RE-START UNTIL IT IS ENERGIZED BY THE START SWITCH.
- IIII FACTORY WIRED \_\_\_\_\_  
FIELD WIRED - - - -

**E**

MCENGLEEVAN  
Steel Treating & Mfg. Co., INC.