



**WE HIGHLY RECOMMEND THAT A GAS PRESSURE GAUGE BE
INSTALLED ON YOUR INCOMING GAS LINE**

**NEVER LOCATE A FURNACE WHERE WORKING ROOM IS
RESTRICTED OR THE AREA IS HARD TO VENTILATE PROPERLY.**

Dear MIFCO Customer:

We would like to thank and congratulate you on the purchase of the McEnglevan machine and accessories, and to share with you our confidence in the quality and reliability of our equipment.

The enclosed operating manual is important. Proper instruction on the maintenance of your machine is very important. Please read your instruction manual completely for best results and maximum machine tool life.

Should you ever need service, it is available through our distributors or directly from the factory. It is the obligation of our distributor who sells you this equipment to conduct field service where possible. Please contact your local distributor first and they will assist you in resolving any problems you may encounter.

We take pride along with you in your purchase of this equipment.

We will be happy to assist you in any way possible to receive optimum results in its operation and use.

For all B, C & T series MIFCO gas fired melting furnaces and MIFCO forges:

In accordance with the National Electric Code, A.G.A., Canadian Standard Association and O.S.H.A. recommendations, this specification sheet must remain a part of this manual. Most of the components are U.L. and A.G.A. listed. The control panel wiring and the ultra-violet combustion safeguard systems are designed to conform to the specifications of the National Electric Code.

Furnaces manufactured beginning in the year 2015 are compliant with NFPA 86 minimum guidelines per below:

- 1) Two valves are required on pilot and main burners
- 2) Visual indication of valve position required for burners above 150,000 BTU/HR
- 3) High and low gas pressure switches required
- 4) Burners above 400,000 BTU/HR require Visual Indication and Proof of Closure

This manual contains the electrical wiring schematic applicable to this particular piece of equipment. If there are any questions, please contact your distributor or the factory. Only licensed electricians or qualified factory representatives should troubleshoot the electrical system of this equipment.

All furnace electric power must be connected to electrical disconnects.

All fuel lines must have manual shut off valves.

Purchased from _____ Date _____

City _____ State _____

Model Number _____ Serial Number _____

Electrical Service Specifications

_____ volts _____ Phase _____ Hertz

Note: Schematic drawings showing different voltages, phase and hertz may be included in this manual. SDS sheets are located in the manual.

Maximum incoming gas pressure and required operating pressure for this unit are listed on a test tag attached to the gas gate valve of the burner system.

IMPORTANT NOTICE:

When connecting the blower to the furnace body, run the scanner cable and the spark wire on opposite sides of the manifold pipe so that they do not touch each other. Should the wire and the cable come within 2 inches of each other, the scanner could obtain a bad reading resulting in start failure.

GAS SERVICE LINE: (updated 1/2015 with dual valve information)

The gas connecting line should be one pipe size larger than the gas inlet size of the mixer and be equipped with a gas regulator and gauge. Main gas line shut off valves must be full flow design to insure maximum gas flow. **Be sure to purge air out of lines before operation.** Low or high gas pressure or inadequate volume will result in flame fluctuation, improper firing, low and high pressure switch activation and slow heating. The easiest method of determining whether or not you have sufficient gas supply to operate the furnace correctly is to operate the furnace with the blower air adjusting valve completely open. At this setting, there should be excess gas available. If excess gas is not available, the utility company may be able to increase gas line pressure, and use a step down pressure regulator at the furnace dual safety shut off valve. Maximum gas pressure allowable by the dual safety shut off valve manufacturer is 7 lbs. THE GAS COMPANY SHOULD BE CONSULTED FOR ADEQUATE PIPE SIZING ON INITIAL INSTALLATION, or where pressure drop is a problem.

The Speedy Melt gas-air mixers will operate efficiently on natural, manufactured, or bottled fuel gas. There are no metering jets, orifices, or spuds to change or remove. When using MANUFACTURED OR BOTTLE GAS as fuel, the utility company should be advised of the furnace BTU rating, so adequate service can be installed. A HIGH FLOW GAS REGULATOR should be set to hold at least eight inches minimum W/C with the furnace operating at minimum input.

GMH High Gas Pressure Switch GML Low Gas Pressure Switch

(Gas pressures are preset at the factory.)

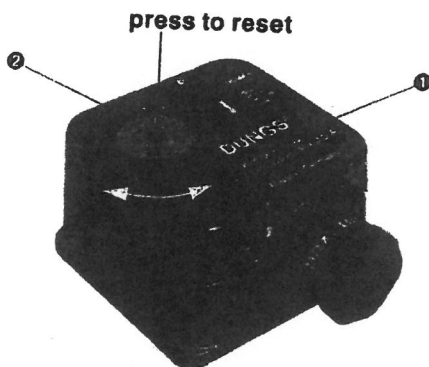

Manual Reset

The NC contact of the GMH breaks when pressure rises above the set point. The NO contact of the GML breaks when pressure falls below the set point. Neither of the switches will return to their former position automatically. To reset, wait until the pressure returns to the normal operating level. Then press and release the clear cover over the red reset button in the center of the yellow dial face; it is not necessary to remove the cover. The neon light indicates a fault condition for the GML and GMH series.

Sample propane setup for B301:

1. 1/4" pipe from tank to regulator.
2. Tank regulator for required BTU for each furnace.
3. 1/4" to 1/2" reducing elbow
4. Regulator for required BTU for each furnace (B301 uses 1" gas solenoid).
5. 3/4" to 1" reducing coupling.
6. 1" pipe 10 feet to furnace.
7. 1/2" pipe between regulators.

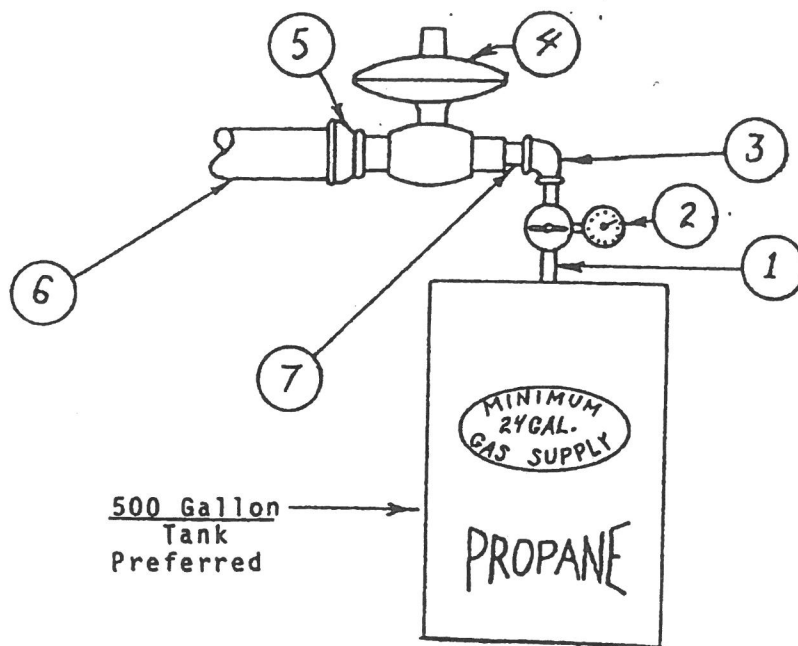

GAUGE SETTING:

2. Set this gauge at 4 lbs.
4. Set this regulator at pressure on furnace test tag.

RECOMMENDATIONS:

- Propane tank should be outside of building.
- (2) Regulator should be outside of building, covered and locked.
- (4) Regulator should be 10 feet from furnace to protect diaphragms inside regulator from heat.
- Purge air from lines.

POURING FLOOR:

It is a good practice to install the furnace on a "pad" of tamped molding sand, clay, or loam, since molten metal or constant heat will damage a concrete floor. By extending the size of the pad into a pouring floor - a safe pouring area can be added to the casting area. A satisfactory pad can be made in the shop by welding a rectangular framework of angle iron. Size will depend on the room available and the instructor's preference, but the pad should be large enough for the furnace plus eight molds. The inner area is then piled and tamped with old molding sand or foundry clay. The pad should be at least two inches thick. Expanded metal, laid on the surface of the earthen pad will help prevent tracking earth or clay through the shop area.

PIT INSTALLATION:

The larger B-702 and B-1501 series furnaces are usually installed in a furnace pit to simplify handling the crucible of metal. Illustrations of the Speedy-Melt Model B-1501 illustrate such installation. Overall furnace dimensions are found in the Relining Section of this manual. Diagrams show both pit and surface installation. THE BLOWER, GAS/AIR MIXER, AND CONTROL SYSTEMS SHOULD ALWAYS BE LOCATED AT FLOOR LEVEL AND NEVER IN THE FURNACE PIT. The controls should be located in a safe, accessible location.

BURNER ADJUSTMENT:

The Speedy Melt furnace is designed with two valve control. This makes it possible to obtain a reducing, oxidizing, or neutral flame depending on the metal being melted. Experience is gained by lighting and observing the flame. Adjusting all two valve burner systems is identical to adjusting an oxyacetylene torch. After the main burner flame has been initiated, the firing rate of the furnace is increased by opening the gas valve slightly until there is an excess of gas in the mixture burning within the furnace chamber. Then open the air valve until the flame draws back to burner tunnel and burns with a blue flame. Continue the adjusting sequence to obtain the maximum burning rate.

FURNACE OPERATION AND STARTUP:

Locate the crucible block in the center of the furnace chamber. ALWAYS use the correct size block and NEVER place the crucible on the floor of the furnace over the drain hole. Doing so causes a cold spot at the bottom of the crucible and retards melting. The block locates the crucible at the proper height for the hottest combustion and reflected heat. If the crucible sticks to the base block, apply fine graphite or silica flour to the top of the block, or wet a piece of corrugated cardboard and drop on the base block just before the crucible is set in place. If the furnace is cold, use the cardboard dry. The paper will char and form a parting layer between the block and the crucible. DO NOT CHARGE METAL THROUGH, OR OBSTRUCT THE LID EXHAUST HOLE IN ANY MANNER WHILE IN OPERATION. If the crucible breaks while in the furnace, the molten metal will flow out the drain at the bottom of the furnace

A layer of high temperature refractory insulation is cast between the pre-burned brick lining and the steel furnace shell. This increases melting efficiency and holds heat loss through the furnace walls to a minimum. Since the insulation is a castable material, a certain amount of moisture is absorbed by the furnace lining. It is recommended that the initial firing periods should not exceed fifteen minutes, to allow the lining to expel the moisture slowly. The moisture may appear as steam or drops of water. Two or three short firing periods will be sufficient to remove excess moisture.

Instructions in the section USE AND CARE OF GRAPHITE CRUCIBLES should be followed as closely as possible. This practice is routine in the foundry trade, and will increase crucible life and prevent failure due to cracking and spalling.

FLAME ADJUSTMENT:

Adjust the firing to low fire, raise the lid, and swing it to the rear. Place the crucible in the center of the furnace chamber. Close the lid, being sure it seats inside the seal ring. Adjust firing rate to full open. IF SUFFICIENT GAS VOLUME IS AVAILABLE, IT SHOULD BE POSSIBLE TO ADJUST THE AIR VALVE TO FULL OPEN WITH AN EXCESS OF GAS SHOWING AT THE LID EXHAUST HOLE. Final adjustment for furnace atmosphere depends on the metal being melted. Aluminum and copper should be melted with as near a neutral atmosphere as possible. This type of atmosphere is obtained by adjusting the gas / air valves until the exhaust shows two to three inches of yellow flame, then close the gas valve until the yellow flame disappears. Melt brass with a slightly rich or reducing flame - have about one inch yellow flame showing in the exhaust. Insufficient or excessive gas pressure will trip the high or low gas pressure switches causing them to need to be reset.

NOTE OF CAUTION WHEN MELTING ALUMINUM:

Due to the high velocity of the flame and the light weight of molten aluminum, THE FURNACE SHOULD BE THROTTLED TO HALF FIRING RATE DURING THE LAST HALF OF THE MELTING CYCLE, or after the aluminum has reached the PLASTIC or MUSHY state.

If the furnace is fired at maximum rate when the aluminum is molten and ready to pour, THE HIGH VELOCITY FLAME WILL PICK UP ALUMINUM PARTICLES FROM THE CRUCIBLE AND EXPEL THEM THROUGH THE TOP EXHAUST HOLE. This condition will not be experienced with heavier metals such as brass or gray iron.

At maximum firing rate, the Speedy Melt Series of furnaces are noisy. This is due to the high velocity flame and the amount of BTUs generated within the combustion chamber to obtain the rapid melting cycles. If the noise is objectionable, the furnace can be operated at a lower input rate with slightly slower melting cycles. However, for melting gray iron, the furnace must be fired at maximum input.

The exposed refractory should periodically be cleaned thoroughly and coated with a refractory sealer.

MAINTENANCE:

All MIFCO furnaces are constructed with hard, pre-burned, sectional refractory shapes. Each brick is made by air ramming the granular refractory particles into a steel mold, forming the desired shape. The shape is removed from the mold, dried to remove all moisture, then fired. Defective bricks that fail during the final burning are discarded. This assures controlled quality refractory for all MIFCO furnaces before assembly into a furnace lining.

We can control quality through the point of manufacture of the furnace, but preventative maintenance is necessary for maximum productive life of the furnace lining. The exposed surfaces of the refractory lining should be resealed when scuffing and wear takes place.

MINRO-WASH REFRACTORY SEALER FOR FURNACE LININGS:

The basic refractory used for our sealer is ground to a very fine powder. It is then mixed with a water soluble bonding agent which develops a mechanical bond to the refractory. When the furnace is fired to a high temperature, the bonding agent burns out and the refractory sealer forms a ceramic bond with the furnace lining. It is available in twenty pound bags and should be stored in a dry warm area. Prepare only the quantity to be used at one time for one application.

REFRACTORY PLASTIC PATCHING MATERIAL:

If the refractory lining has been chipped or broken, and the damaged areas are too large to be filled with refractory sealer, they should be filled with patching material. The plastic patching material consists of the same refractory as the sealer, except a coarser grain size is used. It is a medium grained, heat setting mix that should be thoroughly tempered with water before use. The material not used must be discarded. Mix with water only the amount needed each time.

APPLICATION OF SEALER AND PATCHING MATERIAL:

Remove all loose scale and foreign material from the surface to be sealed. Wire brush to remove flux and old loose sealer. Excessive flux and spilled metal are detrimental to refractory and should be removed. Prepare the surface by priming with a saturated solution of sodium silicate. This material is available from drug or foundry supply houses. Brush or sponge the solution liberally on the refractory.

The refractory patching material should be used at this point to fill larger holes. Saturate damaged areas with primer or water. This forms a strong bond between the refractory and patching plastic. Place a layer of patching plastic with a maximum thickness of 1/8" into the area being filled. The thin patch should be allowed to dry for one hour, then heat the area to a red temperature by using the furnace. When the furnace has cooled, add another thin layer, not exceeding 1/8" thickness over the original layer, using the above instructions for the second patch. Successive thin layers should be applied and burned until the patch conforms to the original contour of the furnace lining. If the procedure of applying and burning in the successive thin layers is not followed, and a heavy patch is used to fill the damaged area, the moisture retained in the center of the heavy patch will generate sufficient steam to cause it to rupture and peel.

After the primer has been applied, and any severely damaged sections have been repaired with plastic patching, prepare the sealer as follows:

Step 1. Use one pint of warm water in a metal container.

Step 2. Sift the refractory into the water while stirring constantly.

Step 3. Allow the mixture to set overnight to completely dissolve the bonding agent.

Step 4. Remove the lid from the furnace so both the bottom and top surfaces can be sealed. With the use of a sponge, saturate exposed refractory with water and immediately brush the prepared sealer into the surface of the refractory lining and lid. Unless the refractory is pre-saturated with water, it will draw the moisture from the sealer, preventing a tight bonding action and the seal coating will peel. (LIGHT COATINGS APPLIED OFTEN, ARE MORE SATISFACTORY THAN ONE HEAVY APPLICATION.)

Step 5. Allow the furnace to dry for a period of at least two hours.

Step 6. Light furnace and fire slowly for about five minutes, then shut furnace down. (THIS PROVIDES HEAT TO EXPEL MOISTURE FROM THE PATCHING PLASTIC.)

Step 7. Allow the furnace to dry an additional hour, then light furnace and increase heat slowly to red heat. The furnace chamber should be inspected and cleaned of any accumulation of slag or spilled metal while the furnace is cold, prior to startup. Proper cleaning and the use of sealer should triple the life of the refractory in your furnace.

THE USE AND CARE OF FOUNDRY CRUCIBLES

COMPOSITION - TYPES OF MATERIAL:

Crucibles are manufactured in two basic compositions; the CLAY GRAPHITE-CERAMIC BONDED, AND THE SILICON CARBIDE-CARBON BONDED TYPES. Both types utilize the refractory materials, graphite and silicon, as conductors of heat and for structural strength. Graphite is predominant in the composition of the clay graphite crucible, while silicon carbide predominates in the silicon carbide crucible. Due to its higher heat conductivity and greater strength, the silicon carbide crucible is more popular in industry. The less expensive clay graphite crucible is generally used in the School Shop. Crucible failure in School Shops is generally due to mishandling by inexperienced students, so the benefits of the more expensive silicon carbide crucible would not be realized.

COMPOSITION - TYPES OF MATERIAL: - (cont.)

Either type of crucible can be used for melting aluminum, brass, or gray iron. However, different metals should not be melted in the same crucible. This practice will cause contamination of each melt and it will be very difficult to get good castings. Different crucibles should be used for each type of metal melted. If gray iron is to be melted in appreciable quantity, a special clay lined silicon carbide crucible is recommended. **DO NOT USE JUST ANY SIZE CRUCIBLE IN YOUR FURNACE, USE THE SIZE FOR WHICH THE FURNACE WAS DESIGNED.**

RECEIVING AND STORAGE:

A great deal of stress has been put on the proper care of crucibles for maximum service life and safety. Several factors are important and should be carefully considered.

DO NOT STORE crucibles as received in their original container. Examine the container, **UNPACK CRUCIBLES IMMEDIATELY**, and inspect each crucible for cracks or damage. **SOUND** each crucible by tapping lightly with a hammer handle. If cracked, the crucible will have a dull sound. Undamaged crucibles will have a clear ring. If the shipment contains damaged pieces, have the delivering carrier acknowledge the damage on your delivery receipt, or notify the carrier of hidden damage and call for immediate inspection.

After inspecting crucibles, they should be **STORED IN A WARM, DRY PLACE**. If it is necessary to stock the crucibles in an exposed, unheated location, they should be moved to a warm area for two or three days prior to using. **EXCESS MOISTURE SHOULD BE REMOVED PRIOR TO TEMPERING..**

DRYING AND ANNEALING NEW CRUCIBLES:

All crucibles should be properly annealed before being put into production. Annealing relieves all strains set up in the crucible during manufacture. This also **DEVELOPS A FULL ELASTIC PROPERTY TO WITHSTAND THERMAL SHOCK** during service. The crucible should be dried as outlined previously, and placed in a warm furnace.

Adjust the furnace burners at idle, or lowest heat input, for the first ten minutes. Increase burner setting gradually to raise furnace temperature to a red heat. Total heating cycle should cover a period of forty to fortyfive minutes. After the crucible has reached a red heat, it can be removed from the furnace, charged with metal, and put into immediate service.

CHARGING THE CRUCIBLE WITH METAL:

Crucibles are usually charged with metal before they are placed in the furnace chamber. The part of the charge consisting of gates and risers, or of clean scrap of equivalent size, is charged first. Ingots and bars are charged last. Turnings or very light scrap should be added into the crucible after the initial charge has become molten. Otherwise, the turnings and light sections will be attacked by the furnace atmosphere, and will be oxidized excessively before the melting temperature is reached. These oxides and impurities are carried into the casting metal, resulting in porous and unsound castings. Heat is transmitted to the light scrap more rapidly by the molten metal with a minimum of oxidation. **ALWAYS BE POSITIVE THAT ANY METAL ADDED TO A MOLTEN BATH IS DRY, OTHERWISE AN EXPLOSION WILL OCCUR.** This is because of steam generation in the molten bath. Ingots should be thoroughly dry, and added to the molten charge with long handled pickup tongs.

ADDING INGOT OR PIG TO THE CRUCIBLE:

Heavy sections of the charge should not protrude above the lip of the crucible or they will be subjected to furnace atmosphere and excessive oxidation. THE INGOTS AND BARS SHOULD BE CUT TO A LENGTH SHORTER THAN THE INSIDE DIAMETER OF THE CRUCIBLE. This is particularly true when adding bars or pig to crucibles of molten metal. Long pieces, when added, will sink and come to rest in a horizontal position. They then expand before melting and press against the sides of the crucibles, causing cracks and premature failure.

PREHEATING CHARGE METAL:

It is very poor practice to preheat scrap or bars by placing them across the exhaust port in the lid of the furnace. Such practice causes excess oxidation of the metal and will result in poor castings. For the same reason, LONG BARS SHOULD NOT PROTRUDE THROUGH THE EXHAUST PORT INTO THE CRUCIBLE. In extreme cases, some of the bars will reach melting temperature, allowing the molten metal to run down inside the furnace lid and walls. This molten metal is oxidized very rapidly and attacks the refractory lining, causing premature replacement of the lid and lining. INGOT CAN BE PLACED AROUND THE LID, WELL AWAY FROM THE EXHAUST PORT.

MELTING CAST GRAY IRON:

If cast iron ingot material is used, we suggest that you purchase a Class 25 or a Class 30 iron. This type of cast iron melts at a slightly lower temperature and has better fluidity than the higher class irons. If new ingot is not available, good cast iron scrap can be used. One type which has good casting features is the scrap cast iron in steam radiators. The original ingot used to produce this quality of casting had to have good casting characteristics and high fluidity. Otherwise, it would not produce the thin walled, steam tight castings required in steam systems.

Cast iron motor blocks and other machinery products should not be used as scrap for remelting in a gas fired crucible type furnace. The pouring temperature of alloyed scrap iron is usually 100 -150° higher than the Class 25 or the Class 30 Iron. The higher temperature needed to melt this alloy is very detrimental to both crucibles and the furnace linings. Pieces of steel or malleable iron scrap should not be added to the crucible charge because they also raise the melting temperature of the iron. In addition to having less desirable casting properties and being harder to pour, the finished castings may be hard and very difficult to machine.

Standard clay graphite or silicon carbide crucibles can be used for melting gray iron, however, the clay or alumina lined silicon carbide crucible is more suitable. Molten iron has an extremely high affinity for carbon, and it will leach or absorb carbon from the inner wall of the crucible during the melt. This will erode the inner surface of the crucible and shorten crucible life. The alumina or clay lined crucible has an inner lining of alumina refractory; which acts as an inert barrier between the molten iron and the carbon in the crucible. The cost of the clay lined silicon carbide crucible is slightly higher than the standard silicon carbide crucible. Availability is the problem, so ample lead time must be considered when purchasing this type of crucible.

Graphitic Carbon should be added to the cast iron scrap when the crucible is filled, prior to setting in the furnace. Certain types of Graphitic Carbon are absorbed rapidly by the molten iron, so care must be taken in selection of the correct Graphitic Carbon Raiser. Approximately three percent, by weight, of Graphitic Carbon Raiser should be added with the charge metal. A suitable material is charcoal briquettes, but they do not furnish the same form of carbon. It is not as readily absorbed by the iron as is the Graphitic type of carbon raiser. Approximately six charcoal briquettes should be added to a #30 size crucible and it should be mixed with the scrap iron. This crucible will hold about 75 lbs. of iron. When charging the crucible with iron, thin sections should be added along with heavier pieces and the ingot.

Melting Cast Gray Iron - (cont.)

The thin sections will melt rapidly and form a molten puddle, which will transfer heat to the heavier sections more rapidly and reduce the over-all melting time. Additional scrap can be added to the crucible as the charge melts down. The Graphitic Carbon will generate additional heat as it burns, but more important, it will protect the molten metal from oxidation during the melt and maintain the carbon content of the cast iron.

It is imperative that both students and operators use cobalt blue goggles when melting iron, to protect their vision from the high temperature radiation. They must check the melt periodically to determine the fluidity of the melt preparatory to pouring the mold. There is usually a heavy slag formation over the surface of the melt so a rod should be used to penetrate the heavy slag to check the fluidity of the molten bath. **DO NOT USE A LANCE PYROMETER WITH THERMOCOUPLE TO CHECK THE TEMPERATURE. THE MOLTEN IRON WILL MELT THE TIP OF THE LANCE.**

An optical pyrometer or a replaceable thermocouple tip, lance type pyrometer should be used to check the temperature of the molten iron. The replaceable tip pyrometer is equipped with a socket type receptacle to which the thermocouple tip is attached. The thermocouple tip, when immersed in molten iron, will resist melting and destruction long enough to get a high temperature reading. **A NEW TIP MUST BE USED FOR EACH TEMPERATURE READING.** This equipment is quite expensive to purchase, and to maintain, except in industrial use.

After the melt has attained the proper temperature and fluidity, remove it from the furnace, then add a cast iron flux material to the crucible. This will change the plastic condition of the slag and make it easier to skim. After the molten iron has been skimmed, it is advisable to add ferro-silicon shot to replace the silicon lost during the melt. Ferro-silicon is usually wrapped in a paper envelope, and plunged beneath the surface of the molten cast iron with a bell plunger. A stainless steel bell plunger is more satisfactory because of the high temperature. It is extremely important that the ferro-silicon is added just prior to the pour. Adding this alloy at an earlier time in the melt will retard or prevent carbon absorption. About one and one half percent, by weight, should be used for crucible melting.

As an added precaution against chill, or, hard spots in the gray iron casting, it is advisable to place an inoculating agent in the mold. One such agent is in the form of a small tablet called Inotab, and is made up of a compound which combines with the iron. It inoculates the iron to prevent the formation of chills and hard spots. The Inotab is placed in the sprue-well of the mold prior to pouring. **IT IS VITALLY IMPORTANT THAT THE MOLD BE Poured CONTINUOUSLY ONCE POURING HAS STARTED.**

Another important factor in pouring gray cast iron is to design the feeding system with larger runners, gates, and risers. The feeding system which would be used for aluminum or brass casings, will not permit a fast enough flow of molten iron into the mold cavity. The molten iron must be free to fill the mold cavity rapidly and completely. Risers will be used more frequently in iron castings than in either brass or aluminum, due to shrinkage normally found in iron solidification. We do not recommend pouring cast iron into petroleum bonded sand, due to the smoke and gas evolution. If petroleum bonded sand is used, the mold should be designed with additional venting. The smoke and gases formed when the hot metal contacts the petroleum bonded sand can then leave the mold cavity freely. It is also important to delay casting shake-out to be sure the hot casting has cooled sufficiently so the oil bonded sand does not ignite and burn.

Melting Cast Gray Iron - (cont.)

The melting furnace should be adjusted so that the air valve is completely open, utilizing the total output of the blower. The gas valve is adjusted so there is a reducing or slightly gas-rich atmosphere in the melting chamber of the furnace. The different pouring temperatures for different classes of cast gray iron and temperatures for malleable irons and steels are as follows:

Metal	Melting Point	Pouring Temperature
Gray Iron Class 20	2150 F	2550 F
Gray Iron Class 25	2270 F	2625 F
Gray Iron Class 60	2370 F	2650 F
Malleable Iron*	2585 F	2800 F Avg.
Steel*	2700 F	2800 F Avg.

*Alloyed Gray Cast Iron, Malleable Iron, and Steel, should be melted in a Cupola or an Electric Induction or Arc Furnace.

The lower two classes of gray iron, #20 and #25, can be poured at lower temperatures, and are the most suitable for crucible melting. Cast Gray Iron alloyed with chromium or nickel, such as the grade used for gasoline engine blocks, transmission housings, etc., will have a casting temperature range which is slightly higher than the Class 60 Grey Iron. Such elevated temperatures are extremely detrimental to the furnace and crucible. These metals **SHOULD NOT BE USED** for crucible melting.

ACCESSORIES:

Correctly designed tongs and shanks should be used, both for safety and to minimize crucible failure. **MIFCO** Tongs and Shanks are designed especially for use with our furnaces.

The **MIFCO** Crucible Tong is designed and manufactured according to the recommendations of crucible manufacturers. Each gripper pad is die coined to uniform shape, and nests the crucible below the bilge diameter. Adjustable stops prevent excessive pressure being exerted on the crucible walls, thus avoiding crushing. All Tongs are equipped with a lifting eye and a safety bar lock.

The **MIFCO** Safety Shank was developed by our engineers at the request of School Shop Instructors and Educational Administrators. It is simple in design, easy to operate, and holds the crucible securely. This prevents accidental dropping and dumping a crucible of molten metal. The holding ring is die coined and formed to insure proper size and shape for secure seating of the crucible.

Automatic temperature control of most of our B, C, and small T series furnaces is not practical from a cost standpoint. These crucible furnaces are designed for fast melting and are fired with high input burners. Consequently, the furnace chamber develops a high thermal head that makes automatic control extremely difficult and cost prohibitive. Normal foundry practice is to use a portable lance pyrometer to check the furnace temperature periodically. When the metal approaches pouring temperature, the burners are throttled down, and the thermal head in the furnace finishes the heat. The crucible should be pulled, fluxed, and poured immediately.

ULTRA VIOLET COMBUSTION SAFEGUARD WITH SPARK IGNITION

MIFCO COMBUSTION SAFEGUARD SYSTEM No. 4 –updated 8/2017

SAFE STARTING:

1. Open the lid and swing away from the burner. (WARNING - DO NOT SWING THE HOT LID OVER BURNER EQUIPMENT.)
2. Open main gas line shut off valve leading to the furnace. This does not include the gas adjusting valve at the mixer.
3. Be sure both mixer gas and air adjusting valves are closed.

IGNITION:

4. Press the start button. This energizes the flame protection circuit. Press the red reset button on the high or low pressure switch that has the light lit up on the multi valve gas valve.
5. There will be a 2 second self diagnostic period when the unit receives power. During this time, the unit checks all circuits for continuity before powering the blower.
6. After the blower starts, the OPR control and INTRLCK lights light up. There is a 30 second purge cycle prior to the spark transformer and main gas coming on.
7. When the purge cycle is finished, the spark transformer and main gas solenoid will receive power. This will be indicated by the PTFI indicator light on the flame supervision chassis. At that time, you have 10 seconds to achieve ignition before the unit shuts down for flame failure. Open the gas adjusting valve slowly (smaller adjusting valve which enters the side of the mixer) until main burner ignites. When the flame is established and is being seen by the flame scanner, the FLAME indicator light on the chassis will be lit. The ignition trial period only lasts for 10 seconds, so burner flame must be established within this time.
8. Adjust the mixer to about 1/3 firing rate. Adjusting any two valve burner system is identical to adjusting an oxy-acetylene torch. Increase the gas slightly until the flame shows a slight excess of gas, then open the air valve to form the flame cone at burner tunnel. IMPORTANT THE MAIN BURNER FLAME MUST BE HELD NEAR THE BURNER TUNNEL OPENING SO THE ULTRAVIOLET SCANNER CAN SEE THE FLAME.

ADJUSTING:

9. Close the furnace lid and continue opening the gas and air valves per step 8 until the air valve is wide open. There should NEVER BE MORE THAN 5 inches of flame coming out of the exhaust port at any time during adjustment of burner.
10. To decrease heat, close the air valve until the exhaust flame at the exhaust port is about 5 inches long. Next, close the gas valve until the flame disappears into the furnace. Repeat the turn down sequence to the desired firing rate. Idle is about one fourth open.

SHUT DOWN FOR POURING OR TEMPERATURE CHECK:

11. IDLE FURNACE PER STEP 10, then press the stop button. This closes the gas solenoid shut off valve and stops the blower. DO NOT CHANGE IDLE ADJUSTMENT OF VALVES. To restart the furnace, press the start button and the furnace will re-ignite at the idle position.

SHUT DOWN TO SECURE FURNACE AT END OF MELTING PERIOD:

12. Press the stop button. Close both of the mixer adjusting valves. Close the gas line shut off valve. Close the furnace cover.

RE-IGNITION AFTER FLAME FAILURE:

- a. Turn off all burner adjusting valves.
- b. Press the stop button on the start-stop station.
- c. Wait 50 to 60 seconds for safety timers to cool off.
- d. Depress the RESET button on the flame supervision chassis.
- e. Open the furnace cover. Repeat ignition steps 4 through 8.

TROUBLE SHOOTING FOR INITIAL START-UP:

A. FURNACE WILL NOT RESTART AFTER MELTING CYCLE AND SHUTDOWN: The gas valve was closed, extinguishing the flame before the stop button was pressed. This simulates a flame failure and initiates the flame failure shutdown cycle. Follow the steps in RE-IGNITION AFTER FLAME FAILURE, to restart the furnace.

B. FURNACE IGNITES SATISFACTORILY, BUT SHUTS DOWN WHEN HEATING RATE IS INCREASED: Too much gas in the mixture. The flame blows away from the burner tunnel, simulating a flame failure. Refer to the information in STEP 8 of IGNITION.

C. FURNACE SHUTS DOWN WHEN FURNACE IS ADJUSTED TO MAXIMUM FIRING: Insufficient gas supply. The excess air extinguished the flame. Have a gas utility company check the gas regulator and size of installation against the BTU rating of furnace.

D. SLOW MELTING: Insufficient gas supply. The operator should be able to open the air valve all the way and still have excess gas available. See the Operating Manual on: OPERATION.

E. FURNACE WILL NOT START AFTER FLAME FAILURE SHUTDOWN: The flame relay has not been reset. See STEP "d" in RE-IGNITION. Insufficient waiting period for cool down of timers. See STEP "c" RE-IGNITION.

SERVICING - TROUBLE SHOOTING:

Problems with MIFCO furnaces with Fireye Controls can be easily isolated by following the approved procedure in the sequence given below. Before starting any trouble shooting, however, make sure of the following:

1. Installation and wiring has been made in accordance with the manufacturer's instructions.

2. The Fireye Chassis is securely plugged in and the top and bottom retaining screws are tightened. The Lockout Switch (white pushbutton) is reset and the high & low pressure switches have been reset and have no lights on.

In the following list, problems are listed first, and the possible causes are listed below in numerical order. Refer to the manufacturer's instruction manual included in this operating manual for proper component and contact identification. It is necessary to have a 20,000 ohm, DC volt meter to perform signal testing. This meter, set on 150 volt AC scale, may be used to check line and load voltages at the identified terminal studs on the components.

A. FURNACE WILL NOT START:

1. No voltage at start button or at UV terminals S1 and S2:
 - a. Power cord not plugged into outlet.
 - b. No power at outlet, (check with meter).
 - c. Disconnect switch is off that feeds outlet.

A. FURNACE WILL NOT START: - (cont.)

- d. Broken wire between outlet and control box.
 - e. Blown fuse that feeds circuit breaker.
 - f. Check the 2 amp control fuse.
2. Insufficient voltage at UV terminals S1 and S2:
 - a. Minimum voltage is 102 volt - 50/60 cycle.
 - b. Maximum voltage is 132 volt - 50/60 cycle.
 3. No voltage to coil of motor starting relay R-1:
 - a. With volt-meter, check wires to relay coil from start / stop buttons.
 4. Unit not properly grounded.

B. MOTOR STARTING AND HOLDING RELAY WILL NOT OPERATE:

1. No action when start button is activated:
 - a. Check for voltage on either side of start button. If there is no voltage, replace the bad switch.
 - b. Check relay coil, gray wire, for voltage.

C. HOLDING RELAY WORKS BUT MOTOR DOES NOT RUN:

1. Check motor overload:
 - a. Check with voltmeter to see if power is passing through to motor. Check from ground to overload.
 - b. Push the reset button on the motor overload.
 - c. Check the heater element on the top of the motor overload to see if it is burnt in half.
 - d. Examine relay contacts.

D. THE MOTOR RUNS, BUT THE SPARK DOES NOT COME ON:

1. Check the spark plug for power:
 - a. Remove the spark plug cap. Hold this cap by the outside corner and hold the cap up to a metal part of the furnace and push the start button to see if there is a spark at the cap.
2. Check the air pressure switch and interlock circuit, making sure the lights on the gas pressure switches are not on.
 - a. Replace the air switch. If you get a spark when you press the start button, you know the old switch is bad.
 - b. With the air switch replaced and the motor running, check UV terminals 2 & 4 for line voltage, 120V. If no voltage is present, replace UV chassis.
3. Check the spark plug:
 - a. Pull off the spark wire and hold by the outside corner of the connector cap. Hold the metal part of the cap close to the burner and press the start button. If it sparks, the transformer is OK. If not, check the spark wire connections on both ends and try again. If there is still no spark and there is 120 volts-on terminals 2 & 4, then you should replace the spark transformer.
4. The spark plug does not fire:
 - a. Remove the plug and look for cracks in the porcelain insulator. If it is cracked, replace with the same electrode.

4. (cont.)

b. If the plug is not cracked, install it back in the furnace. The gap between the wire tip of the plug and the end of the burner nozzle should be 1/16" to 1/8". This can be adjusted by bending the electrode wire, swiveling the electrode, and then tightening the clamping nut to hold it in place. Observation can be made with a mirror inside the furnace or through the UV Scanner observation port. In either case, **BE SURE THE GAS IS OFF.**

E. THE MOTOR RUNS, THERE IS A SPARK, BUT NO GAS:

1. Scanner does not see spark:

Remove the scanner to see if the sight tube is blocked.
Wipe off scanner bulb with soft cloth or tissue and replace.

2. Broken Scanner wire:

a. Check for cuts or mashed conduit.

3. Ignition signal testing using a 20,000 ohm per volt DC volt meter:

Connect the meter to terminals S1 & S2.

Set the volt meter on the 10 volt DC scale and initiate a normal start up, but with the gas valve CLOSED. The meter should read between 4 1/2 and 5 volts. If the-meter goes backwards, reverse the leads. If the reading is less than 4 1/2 volts, the scanner needs to be replaced.

F. DUAL MULTI VALVE WILL NOT OPEN:

1. Check interlock light on chassis. If it is flashing, check high & low pressure switches for light.
If light is on, press switch reset button.

2. After checking all of the above, check terminals 2 & 3 on UV Chassis for line voltage:

a. Put the volt meter back on the AC-250 volt scale and put the leads on terminals 2 & 3. Start the furnace, and when the unit goes to Main Flame, terminal 3 should be energized, reading 120 volts. If it is not, and every thing else proves out, the chances are that the UV Chassis is bad and needs replacing.

3. Terminal 3 is powered but the solenoid still will not open:

a. Check for broken wires or loose connections.

b. The solenoid wires can be taken loose by a qualified electrician and powered with 120 volts to see if it will open. If it does not open, it will have to be replaced.

c. Check to see that the gas pressure is not higher than the rating on the valve nameplate.

G. MAIN FLAME SIGNAL TESTING:

1. Same procedure as STEP E - 3

H. MAIN FLAME DOES NOT LIGHT:

1. Gas valve shutoff someplace in building.

I. MAIN FLAME LIGHTS AND GOES OUT AFTER 10 SECONDS:

1. Flame not adjusted properly:

a. It is best to get the furnace flame at least half way open before the spark goes off, especially on a cold start up.

J. FURNACE SHUTS DOWN WHEN IT IS ADJUSTED TO MAXIMUM FIRE:

1. Insufficient gas supply:
 - a. Excess of air extinguishes the flame. Have the gas utility company check the gas pressure with the furnace running. If the pressure drops too low, the gas supply is inadequate.
 - b. Not enough gas in adjustment, the flame should come out of the exhaust port about 3 inches.
2. Too much gas:
 - a. The flame is burning away from the burner port. The UV Scanner cannot see flame and turns off gas.

K. SLOW MELTING:

1. Insufficient gas supply:
 - a. The operator should be able to open the air valve all the way and still have an excess of gas after the flame has been balanced.
2. Low service line voltage:
 - a. The voltage on the service line should be 115 volts. Low voltage causes the rpm of the motor to drop, which results in a reduced volume of air.
 - b. Bad bearings will also slow down a motor.

L. FURNACE WILL NOT RESTART AFTER STOPPING:

1. Gas valve was shut off before stop button was pressed:
 - a. The reset has kicked out. Push the Reset Button on the UV Chassis and low pressure switch.
2. UV Chassis may be going out.
3. Gas supply marginal and / or fluctuates:
 - a. When starting with the valves in a set position and the gas supply or pressure changes, like when a boiler comes on, the valve setting would not be right and the unit would not start.

M. FURNACE WILL NOT START AFTER FLAME FAILURE:

1. Not enough time has elapsed for blower to stop spinning and allow the air switch to reset:
 - a. Allow blower to stop spinning then press reset button on UV Chassis. Check for lights on high & low gas pressure switches. If lights are on, press reset button.
2. Bad UV Chassis.
3. Bad UV Scanner.
 - a. Check and replace if necessary.

N. ELECTRICAL SEQUENCE:

1. Press the start button and the system performs- self check.
2. Holding coil pulls in and motor starts.
3. Air switch closes, powering high then low pressure gas switches and then powers terminal 6 in UV chassis.
4. Terminals 4 and 3 powered. Ignition transformer powered and ignition timing starts. Main gas solenoid powered.

N. ELECTRICAL SEQUENCE - (cont.):

5. Gas in scanner ionized, allowing power to flow between electrodes.
6. Main flame is proven and stays on.
7. Flame failure for any reason cuts off power to terminal 4 and 3 in 3 seconds.
8. Alarm light comes on.
9. Push reset button.
10. Blower failure, air switch opens - cutting power to dual multi valve. Blower runs another 10 seconds and turns off.

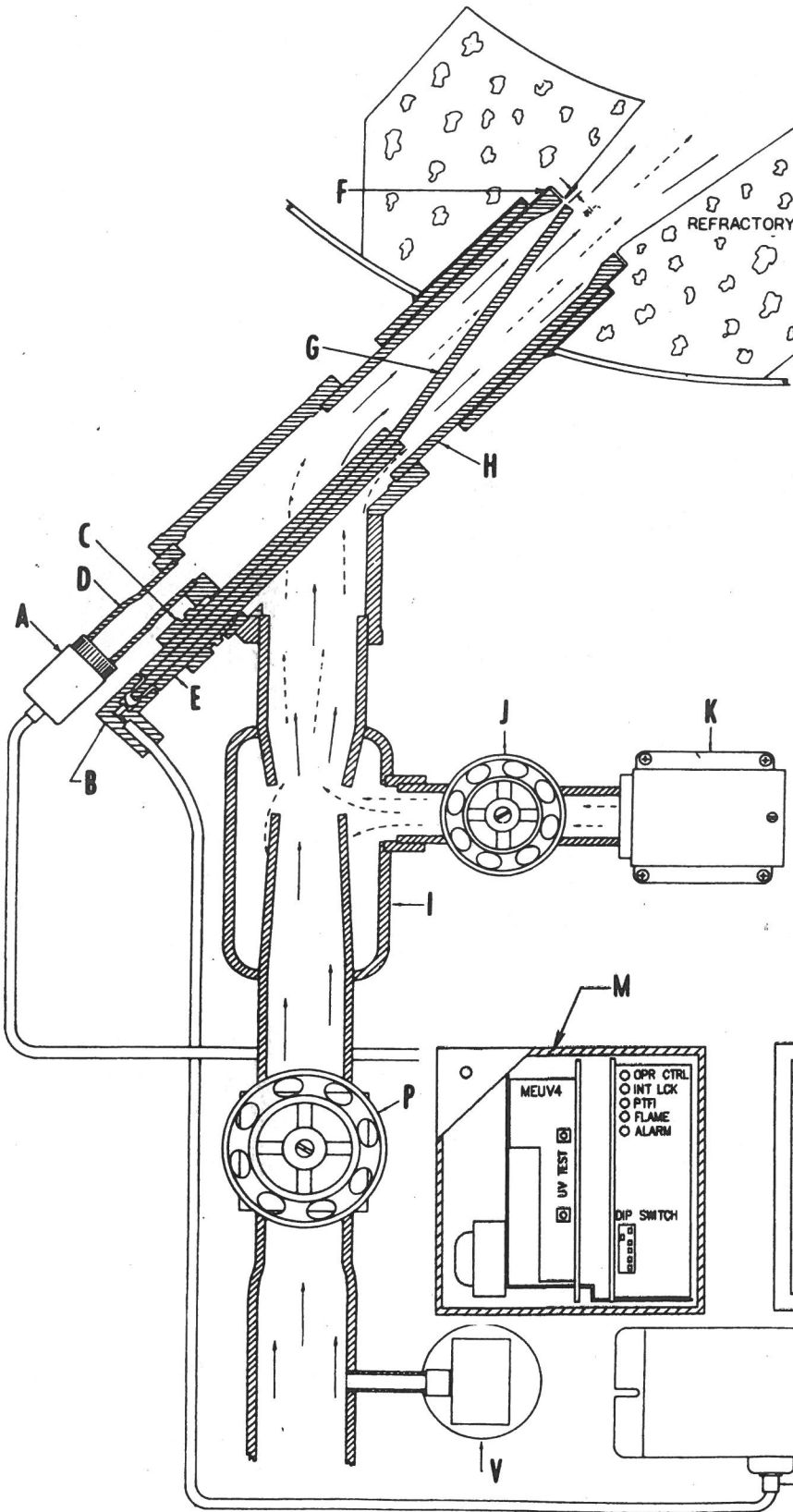

- A Ultra Violet Scanner
- B Ign Electrode Connector #004070
- C Ignition Electrode Clamp #003408
- D 3/8 x 1/2 Reducing Nipple #003024
- E 7" spark electrode #004068 or 4" spark electrode #004067
- F Spark Electrode Gap 1/8"
- G Steel Electrode End
- H Burner Nozzle
- I Gas Air Mixer
- J Main Gas Adjusting Valve
- K Dual valve
- L Start Button #003662
- M UV Chassis #004445
- N Stop Button #003663
- O Control Box Enclosure
- P Main Air Adjusting Valve
- Q Red Flame Failure Alarm #003906
- R Control Relay
- S Contactor #003930
- T Control Fuse Holder #003600
- U Motor Overload Relay
- V Air Pressure Switch #004226
- W Ign Wire Ring Terminal #003712
- X Ignition Transformer 10000v #004300

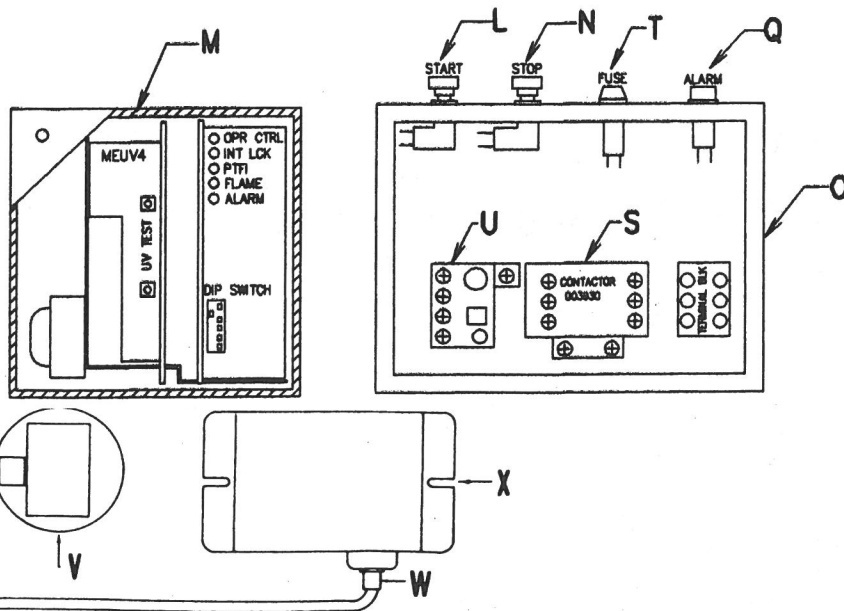

SAFETY SYSTEM NO. 4 UV

Installation of Spark Electrode 4 UV Safety System

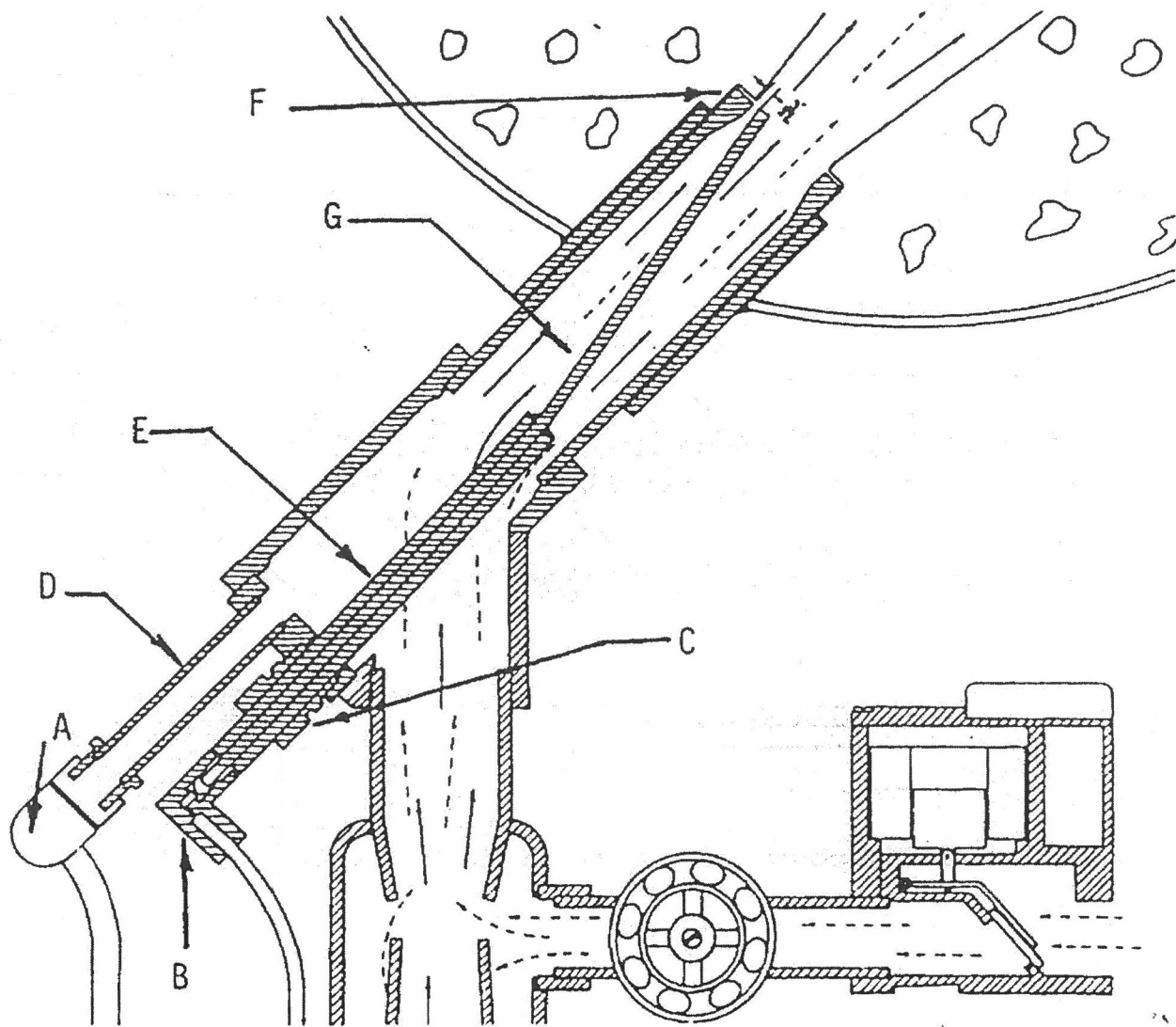

Step 1. Remove scanner shield covering burner tip assembly.

Step 2. Remove the Ultra-Violet Scanner head "A".

Step 3. Remove spark connector "B" and brass electrode lock nut "C".

Step 4. Remove old spark electrode.

Step 5. Put a light inside the furnace chamber, at the end of the tunnel, and insert new spark electrode.

Step 6. The steel electrode "G" is bent at an angle. Look through the scanner tube "D" and revolve spark until spark gap "F" is 3/32" maximum. Be sure the porcelain extends beyond the brass lock nut at least an inch.

Step 7. Tighten the brass locking nut just tight enough to prevent the electrode from moving. (Tightening the nut too tightly will break the porcelain.)

Step 8. Replace spark wire to the electrode. Press the start button and observe the spark by looking through the scanner tube "D".

Step 9. If the spark is satisfactory, replace the scanner head "A", press the start button and light the furnace.

PREVENTATIVE MAINTENANCE

For Model C-10, C-20 Speedy Melt

Electrical System

Always check start stop buttons, to make sure they remain tight in the control box. Loose buttons can cause the wire connectors inside to pull away from the buttons, thus causing a short or other failures.

Make sure that the UV cover is always in position. If the cover were missing, this would allow for the bumping of the spark wire and possible disconnection of the wire, and also damage to the scanner cable.

Make monthly checks of the spark wire to make sure that the angle connector is tight on the wire, and also pushed up tight on the electrode. At the same time, remove the scanner from the swaged nipple and clean the glass glove with a clean cloth.

Lid & Lid Lift Assembly

The jack tube assembly should be greased at least once a month. This will allow for easy rotation of the assembly. This unit is equipped with two lids. The top can be left open allowing you to melt within a cast iron pot. The pot rests on top of the four section lid. When melting within the chamber using a crucible, always make sure that the top cover is closed down at all times, while firing the furnace. This unit is supplied with a chimney on the side to allow for exhaust escape. Always remember to remove the lid handle from the fulcrum pin, while the furnace is in operation. Leaving the handle in position, could result in serious burns to the hands.

Shell Assembly

Always make it a practice to check the furnace shell for what we call hot spots. Be mainly concerned with the area around the burner guide tube. You will notice discoloration of the paint in this area, but only be alarmed if you should see a red glow to the shell. This may indicate that the end has burned off the burner nozzle, allowing the flame to direct itself back into the insulation and thus causing damage to the shell. If you should notice this, shut the furnace down at once. Your first step would be to remove the bolt holding the blower nozzle to the side of burner guide tube. Then pull the blower unit away from the side of the furnace, and check the condition of the burner nozzle. If the end of the nozzle is burnt away, replace it. Simply place the unit up in a vice, or use two pipe wrenches to remove the old nozzle. It would also be advisable to remove the top cast iron seals, and chisel your way down into the insulation, just above the burner guide tube. Recast new insulation in this area, as it has a tendency to deteriorate from the high heat. Then you can place the blower unit back into the side of the furnace shell, and be sure to put the bolt back in position holding the blower to the shell.

Firing Chamber

Make regular checks for cracks in the liner bricks, and also for loose mortar between the rows of brick. If there are open gaps between the brick, the flame can penetrate and erode the insulation, thus causing hot spots on the side of the shell.

Firing Chamber - cont.

At least once a month, take a putty knife and scrape the loose refractory, allowing it to fall to the bottom of the chamber. Then, remove with a vacuum. After the removal of all the loose materials, find an old paint brush and a can of water. Brush a liberal coat of water on your bricks to allow your new application of sealer to adhere to the bricks. **Keep in mind that thin applications of sealer are better than one heavy coat.** A thick coat of sealer will flake off on the first firing, and fall to the bottom of the chamber. It is best to fill all large openings with thick material then thin your mixture down and apply at least three very thin coats with a low firing between each application. Pull the lid assembly up out of the jack pipe, and turn the lid upside down on the floor, to allow you to apply the sealer to the bottom side of the bricks. You can then place the lid back in position and apply a coat of sealer to the upper surfaces. **Keep in mind that continued maintenance of the chamber is to your advantage, as it prolongs the life of the brick.** Always keep any loose metals out of the chamber. If liquid metal is allowed to run down in and around the bottom brick, it will work its way under the liners, thus causing the liner bricks to start working their way upward, as the metal hardens up.

It is advisable to make sure that the drain hole in the bottom of the furnace is always open and not blocked with hardened metal. This is an escape route for the metal, in case of a crucible break. The metal is supposed to flow into the small valley, under the base block, and out on the floor. The bottom is designed in this manner to prevent all the metal from backing up into the burner port in case the crucible should break. Metal in the burner port, can cause major repair costs.

Reline kits are available for this unit. The shipping is usually two weeks from the receipt of your purchase order. Shipped by truck, freight collect.

Preventative Maintenance For Model B-160

Electrical Systems

Always check start stop buttons, to make sure they remain tight in the control box. Loose buttons can cause the wire connectors inside to pull away from the buttons, thus causing a short or other failures.

Make sure that the UV cover is always in position. If the cover were missing, this would allow for the bumping of the spark wire and possible disconnection of the wire, and also damage to the scanner cable.

Make monthly checks of the spark wire to make sure that the angle connector is tight on the wire, and also pushed up tight on the electrode, At the same time, remove the scanner from the swaged nipple and clean the glass glove with a clean cloth.

Lid & Lid Lift Assembly

The jack tube assembly should be greased at least once a month. This will allow for easy rotation of the assembly. Make sure that when the lid is raised, that it raises level. After a period of time, the lid will have a tendency to raise in the back before it raises in the front. If the lid isn't raising level, loosen the lock nuts on the lifting rods and back them off a couple of turns, then tighten the bottom nuts which will raise the lid up. Continue to tighten the nuts until the lid raises properly. Always remember to remove the lid handle from the fulcrum rod after the furnace has ignited and the lid is closed. If the handle is left in that position, it will become very hot. Lay the handle aside for easy access.

Shell Assembly

Make it a practice to always check the furnace for what we call hot spots. Be mainly concerned with the area around the burner guide tube. You will notice a discoloration of the paint in this area, but only be alarmed if you should see a red glow to the shell. This may indicate that the end has burned off the burner nozzle, allowing the flame to direct itself back into the insulation and thus causing damage to the shell. If you should notice this red glow, shut the furnace down at once. The first step would be to loosen the small bolt that is holding the blower to the side of the shell. Pull the blower away from the side of the furnace, you may have to use a twisting motion, if there is a problem with the exterior of the nozzle. The nozzle might be in such bad shape, that you may have to cut it off flush with the burner guide tube. If you are able to pull the whole assembly away with out problems, place the pipe assembly in a vise, and proceed to remove the old nozzle, and install the new one. After the new nozzle is installed, you may have to re-adjust your spark plug. Then place your pipe work back in position as you removed it, and reattach your bolt to the side of the shell.

Firing Chamber

Make regular checks for cracks in the liner bricks, and also for loose mortar between the rows of brick. If there are open gaps between the brick, the flame can penetrate and erode the insulation, thus causing hot spots on the side of your furnace shell.

At least once a month, take a putty knife and scrape the loose refractory, allowing it to fall to the bottom of the chamber, and remove with a vacuum. After the removal of all the loose materials, find an old paint brush and a can of water. Brush a liberal coat of water on your bricks to allow your new application of sealer to adhere to the bricks. **Keep in mind that thin applications of sealer are better than one heavy coat.** Thick coats of sealer will flake off and fall to the bottom of the chamber. It is best to fill all large openings with thick material, then thin the mixture down and apply at least three very thin coats, with a low firing between each application. Make sure that the drain hole in the bottom of the furnace chamber is always open and not blocked with hardened metal. Do not allow spilled metals to get down in around the wall area where the bottom and side liner bricks come together. Continuous melting and re-hardening of this metal will cause your side liner bricks to rise. If this is allowed to happen, the next thing you will experience, will be that your lid will not open or close as it should. At this point you will have to re-line the furnace chamber.

Electrical System

Make frequent checks in your control box to see the lock nuts on the back sides of your stop and start buttons are tight. Loose buttons can cause the wire connectors inside to pull away from the buttons, thus causing a short or other failures.

Do not run the unit without the UV protection cover in position. If the cover is missing, this will allow for bumping of the stark wire, and possible disconnection. The scanner cable must also be protected at all times.

Make monthly checks of the spark wire to make sure that the connectors are tight on the wire, and pushed up tight on the electrode. At the same time, remove the scanner from the swaged nipple, and clean the glass with a clean cloth. If the glass on the scanner is dirty, it will not be able to see the spark, thus causing ignition failure.

Do not allow the conduit going from the ultra violet controller to the motor to be loose from their connectors. Exposure of the wire from the conduit, could cause the wire to get burnt, or cut, thus causing failure of the equipment. One last thing is to make sure that the scanner and spark cables are fastened up around the manifold pipe. Do not allow the cables to lie on the floor, being walked on, and getting mashed. This can also be cause for machine failure.

Lid & Lid Lift Assembly

Make it a practice to grease the jack tube assembly at least once a month, allowing for easy rotation of the assembly. Make sure that when the lid is raised, that it raises level. After a period of time, the lid will have a tendency to raise in the back before it raises in the front. Do not allow the lid to drag across the top of your side liners or the cast iron top seals. This will cause damage to the front edge of your lid brick. In order to correct this problem, loosen the lock nuts on the lifting rods and back them off a couple of turns, then tighten the bottom nuts up, which will raise the lid upward. Continue to tighten the nuts until the lid raises level.

If you notice that your lid bricks are uneven, when the lid is closed, loosen the lid band and take a rubber mallet and very carefully hammer the bricks down flush on top of the side liners, then tighten the nut on the bolt. Do not over tighten the nut, as too much pressure will cause the lid sections to break and fall down into the chamber.

Always remember to remove the lid handle from the fulcrum rod after the furnace has ignited and the lid is closed. If the handle is left in position, it will become very hot, and could cause a severe burn to the hands, if you are not wearing gloves. Lay the handle aside for easy access.

Shell Assembly

Frequently check your furnace shell for what we call hot spots. Be mainly concerned with the area around the burner guide tubes. You will notice the paint will turn brown in this area. This discoloration is ok as the temperature is only 500 degrees. If the shell discolors anywhere else there may be a problem with the brick lining. Check the joints of the bricks for any spaces. The inside of the furnace may need a coating of refractory sealer.

Shell Assembly - cont.

It is our suggestion that you check in the furnace chamber with a mirror and look at the burner ports for any sign of damage of the burner nozzles. If there is deterioration we advise pulling the nozzles out and checking them. Replace if need be. There is a union at the back of the manifold. Loosen this union and the burner nozzles and manifold will pull out of the furnace shell. The nozzles can then be replaced. It is advisable to always keep a spare set of nozzles on hand.

Firing Chamber

Make regular checks of your chamber lining, looking for cracks in the bricks, or loose mortar between the rows of bricks. If you find open gaps between the brick, they must be filled at once, as the flame can penetrate and erode the insulation, thus causing hot spots to the side of the furnace shell.

At least once a month, take a putty knife and scrape the loose refractory from the sides of your chamber, and remove with a vacuum. After the removal of all loose materials, find an old paint brush, or sponge, and a can of water. Brush a liberal coat of water on your brick to prepare them for the new application of RS sealer. The application of the water will keep the brick from soaking all the moisture out of your sealer before you cover the whole inside of the chamber. **Keep in mind that a thin application of sealer is better than one heavy coat.** Thick coats of sealer will flake off and fall to the bottom of the chamber. It is best to fill large openings with thick material, then thin your mixture down, and apply at least three thin coats over the entire chamber, with a low firing between each application.

Always make sure that the drain hole in the bottom of the furnace chamber is open and not blocked with hardened metals. It is also a good idea to work your drain plug bricks back and forth, to make sure that they work freely. Do not allow spilled metals to block the drain escapes. Also, do not allow spilled metals to penetrate down in and around the area where the bottom brick and the side liners come together. If this is allowed to happen, the melting and re hardening of the metals will cause your side liners to rise upward, thus causing a major problem with the opening and closing of your lid. Continuous rubbing of the brick surfaces, under pressure, will cause major damage to your lid brick, as well as the top of your liner brick.

Relining kits are available for all furnaces that we manufacture. The delivery on any reline kit would be at least two weeks from the time of order placement. All reline kits will have to be shipped by truck, because of their weight, and size.

Always remember that continued maintenance will prolong the life of your furnace, and in the long run, cost you less in repairs.

RELINING INSTRUCTIONS

INSTRUCTIONS FOR REPLACING THE LINING AND LID FOR SPEEDY MELT STATIONARY CRUCIBLE FURNACES.

MODELS: B-16, B-160, B-30, B-70 SINGLE BURNER SERIES

MODELS: B-301, B701, B-702, B-1500, B-1501 DOUBLE BURNER SERIES

EACH RELINING KIT CONTAINS ALL REFRACTORY SHAPES, REFRACTORY MORTAR AND INSULATION, AND COMPLETE INSTRUCTIONS TO RELINE AND RENOVATE YOUR FURNACE.

LOCATE THE SPECIFIC PAGES OF THIS SECTION OF THE SERVICE MANUAL COVERING YOUR MODEL FURNACE. IT SHOWS LINE DRAWINGS AND MATERIAL LISTS.

PREPARING THE REFRACTORY CASTABLE INSULATION:

Each relining kit contains enough insulation to pour between the hard brick lining and the steel shell of the furnace. Dump the pre-mixed components into a box similar to a plaster mixing box. Add water so that the insulation will have about the same consistency as plaster. Pour the mixture between the refractory lining and the steel shell. Vibrate or rod the insulation to remove any trapped air from the space between the brick and the shell. This is extremely important around burner ports and the furnace bottom. Further information is contained in the instruction sections.

RELINING INSTRUCTIONS FOR C-9, C-10, C-20 Soft Metal Melters

The Speedy Melt furnaces have been designed so that relining is easily and rapidly done. Complete relining kits are available as a package unit. These kits include all replacement refractory shapes, insulation and correct type mortar.

Structural parts of the furnace which are subject to normal abuse and may need replacement are available. See the operating and maintenance instructions for these parts reference. Relining procedure is as follows:

1. Remove blower, mixer-burner and pilot assembly from furnace. Remove lid lift assembly by lifting out of base tube.
2. Remove lid ring bolt and remove lid brick. Remove front bolt from ring band clamp and remove four ring brick sections. Replace lid band if damaged or burned.
3. Remove four segments of top cast iron seal by removing four hex nuts on top of furnace chamber. Remove all insulation and refractory from furnace shell. Remove and replace the seal hold down bolts if broken. Support the ears, or use gear puller to prevent bending, hold down ear.
4. Mix part of refractory sealer to consistency of heavy cream to use for mortaring joints.
5. Model C-10 - Place bottom row of liners in center of the shell, locating burner brick on burner guide tube and cement into place. Cement I.D. of burner tunnel and O.D. of guide tube to seal against flame leakage. Insert finger in burner guide tube and remove excess cement. Model C-20 - Place row one of liner bricks down in the bottom of the shell and center, making sure burner brick is in line with hole on side of shell.
6. Place a hand full of sealer in the bottom of the shell, and place the bottom brick down in place with grooves up.
7. Place a row of sealer on top of row one bricks. Place second row of bricks on top of row one and align the exhaust liner with the chimney. Cement exhaust sleeve liner in place even with I.D. of furnace chamber. Press row of bricks down to be sure of a good seal. Be sure top ring of liners is level to form seat for cover.
8. Mix pre-mixed insulation with enough water to make a pouring consistency. Pour insulation between shell and refractory lining. Prod while pouring to form an even distribution of insulation. Fill to height of liners. Let insulation set for approximately 20 minutes. Now take a rubber mallet, and tap all around the side of the shell. The insulation will settle down. Now, add more insulation to fill gap back up to the top of the bricks.
9. Replace top seal segments and bolt down in place. Replace lid lift assembly after applying a thin layer of grease to tube.
10. Locate the pot ring bricks. Dip the tongue and groove ends in the sealer, then place the bricks on top of the liners forming your circle. Now spread the lid band, placing it around the bricks aligning the lugs with the notch in the bricks. Do not over tighten. Now, place your cover brick in place and put band around it.
11. Apply small amount of refractory sealer to burner nozzle and reassemble. Be sure burner enters to bumper lock. Replace pilot unit, (if unit has one), and seal with plastic sealer.
12. Mix balance of refractory sealer to consistency of latex paint and cover all exposed refractory with a single coat of sealer. It is better to brush several light coats on instead of one heavy coat. A heavy coat will peel off. Furnace should set for 24 hours to cure insulation, then fire for one hour to remove moisture. The following day, fire as desired.

**OPN 032030 List of Contents for C-9
Relining Kit**

Part No.	Qty.	Description
008056	1	Bottom Brick
008050	6	Solid Liner
008051	1	Burner Brick
008052	1	Exhaust Side Liner
008053	1	Exhaust Liner Tile
008059	1	Cover Brick
008057	1	Chimney Brick
008173		Refractory Sealer
008141		Matrilite 28

OPN 032002

List of Contents for C-10 Relining Kit

Part No. Qty. Description

008056	1	Bottom Brick
008050	6	Solid Liner
008051	1	Burner Brick
008052	1	Exhaust Side Liner
008053	1	Exhaust Liner Tile
008054	4	Pot Ring Bricks
008055	1	Cover Bricks
008057	1	Chimney Brick
008173		Refractory Sealer
008141		Matrilite 28

**OPN 032003 List of Contents for C-20
Relining Kit**

Part No. Qty. Description

008007	1	Bottom Brick
008005	6	Solid Liner
008009	1	Burner Brick
008061	1	Exhaust Side Liner
008062	1	Exhaust Liner Tile
008060	4	Pot Ring Bricks
008059	1	Cover Brick
008058	1	Chimney Brick
008173		Refractory Sealer
008141		Matrilite 28

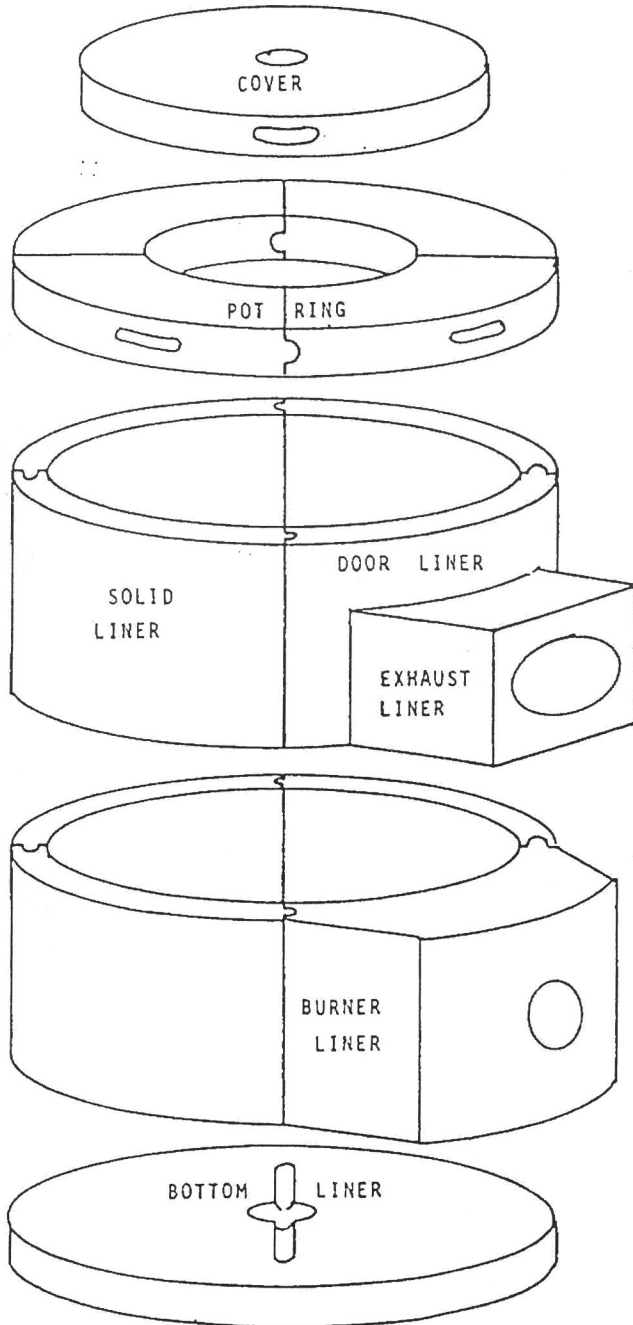

C-9 and C10

10/28/2016

OPN	DESCRIPTION	QTY
A	010070 Lid Lift Handle Assembly	1
B	010025 Lever Handle Assembly	1
C	010020 Lid Lift Housing Assembly	1
D	001207 3/8 x 1 1/2" hex hd bolt	2
E	002017 3/8" Lock Nut	3
G	100050 C10 (only)- cover band	1
H	001213 3/8-16 x3" Hex Hd Bolt	2
I	002015 3/8-16 Hex Nut	2
J	100041 C10 (only)- Pot Ring Assembly	1
K	100090 C9 (only)- Cover Assembly	1
L	008600 Top Seal Segment	4
M	000908 5/16"x 1 3/4" Hex Hd Bolt	4
N	002012 5/16" Jam Nut	4
O	100021 Shell Assembly	1
P	006600 1 1/2"x 6" Burner Nozzle	1
Q	002008 1/4-20 Hex Nut	2
R	000606 1/4" x 3/4" Slotted Rd Hd Screw	1
S	003362 1 1/2" Y Branch	1
T	006665 1 1/2" UV Plug	1
U	003408 1/2" to 3/8" brass fitting	1
V	004106 UV1A3 Flame Scanner	1

W	004068	7" Spark Electrode	1
X	006690	UV Protection Cover	1
Y	*003789	Dual valve-no proof of closure Dungs#DMV-D 701/602 224-842	1
Z	003044	1/2" x 3" Nipple	2
AA	003427	1/2" Gate Valve	1
BB	003043	1/2" x 2" Nipple	1
CC	006030	GM50 Gas Air Mixer	1
DD	003429	1" Gas Gate Valve	1
EE	003086	1" x 2" Nipple	1
FF	003222	1 1/2" x 1" Reducing Coupling	1
GG	003107	1 1/2" x 2" nipple	1
HH	004226	Air Pressure Switch	1
II	004134	F1M Blower with Motor	1
JJ	006200	6 1/2" Blower Stand	1
KK	003002	1/8" x 2" Nipple	1
LL	003024	1/2" x 3/8" Reducing Nipple	1
MM	002360	Eye Bolt	1
NN	100655	Burner Retention Tab	1
OO	002008	1/4" FHN Nut	1
PP	002112	1/4" Lock Washer	1
QQ	003816	Low Gas Pressure Switch	1
RR	003780	High Gas Pressure Switch Dungs #GMH-A2-4-4 266924	1
SS	003836	Visual Indicator Dungs# 217-665A	1
VV	004300	Ignition Transformer 10000v	1
WW	003365	1/2" Black Union	1
XX	003906	Red Light	1
YY	003600	Fuse Holder	1
ZZ	003663	Stop Button	1
A1	003662	Start Button	1
B1	004097	Extender	1
C1	004445	Fireeye Chassis Complete MEC120	1
D1	002111	1/4" flat washer	1
E1	003206	1 1/2" Coupling	1
F1	003128	1 1/2" x 6" Nipple	1

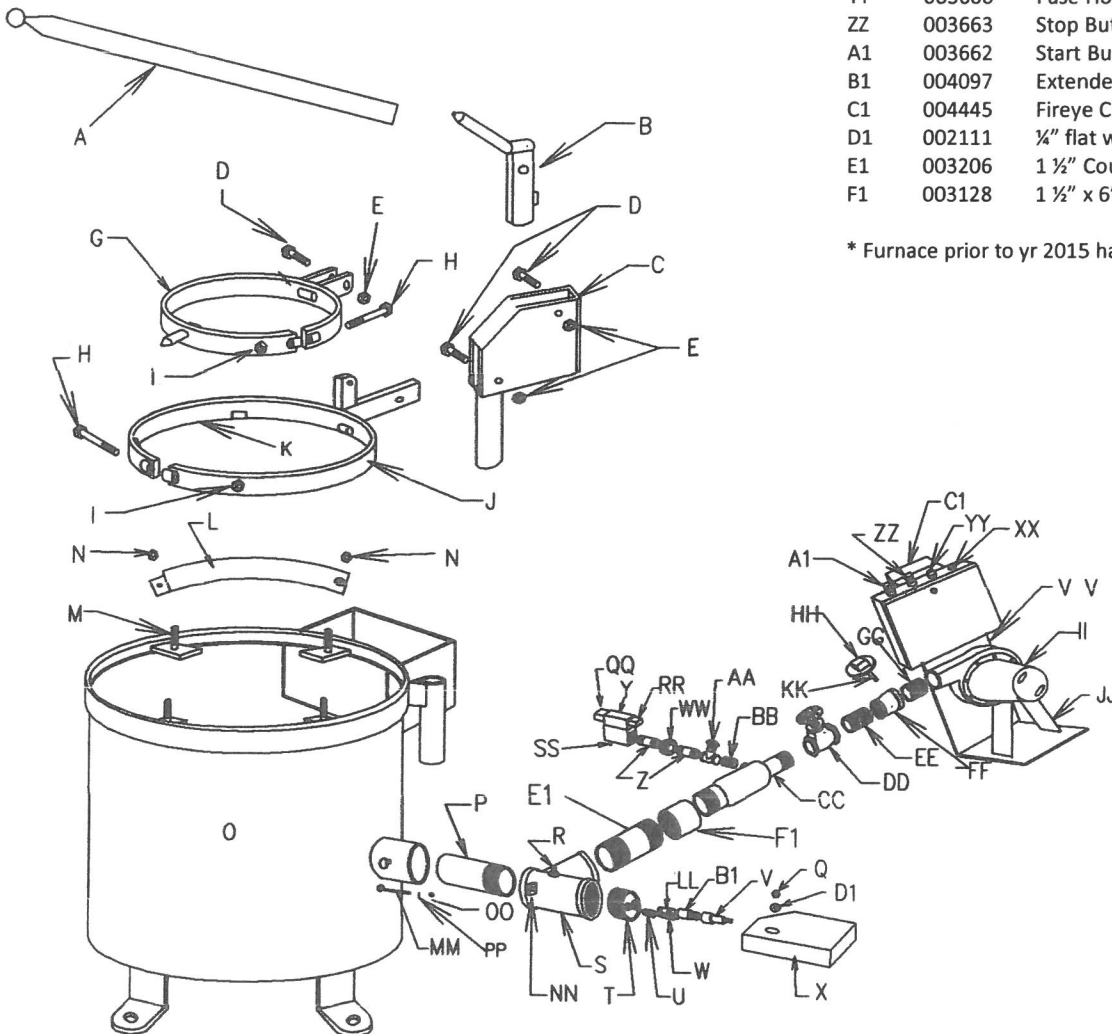

* Furnace prior to yr 2015 have 004213 1/2" solenoid valve

McEnglevan C-20 Parts Listing 04/2019

	OPN	DESCRIPTION	QTY		OPN	DESCRIPTION	QTY
				Z	006690	UV Protection Cover	1
A	010070	Lid Lift Handle Subassm	1	AA	006060	GM100 Gas Air Mixer	1
B	010045	Lever Handle Assembly	1	BB	003341	1" x 3/4" Bushing	1
C	002423	3/8" x 3/4" Spring Pin	1	CC	003062	3/4" x 2" Nipple	1
D	002467	R8ZZ Bearing and	1	DD	003428	3/4" Gas Gate Valve	1
	010009	Bushing	1	EE	003064	3/4" x 3" Black Nipple	2
E	010040	Lid Lift Housing Subassm	1	FF	003789	Dual valve-Dungs#	1
F	001209	3/8" x 2" Hex Hd Capscrew	3			DMV-D 701/602,224-842	
G	002017	3/8" Lock Nut	3			Without proof of closure	
H	100250	Cover Subassm Lid Ring	1	GG	003431	1 1/2" Air Gate Valve	1
I	001213	3/8-16 x 3" hex Hd Bolt	1	HH	003107	1 1/2" x 2" Nipple	1
J	002015	3/8-16 Hex Nut	2	II	003224	2" x 1 1/2" Reducing Coupling	1
K	100241	Pot Ring Subassm	1	JJ	006220	10" Blower Stand	1
L	001215	3/8-16 x 3 1/2" Hex Hd Bolt	1	KK	004331	#175 blower with impeller	1
M	008602	Top Seal Segments	4			Less motor	
N	000908	5/16" x 1 3/4" Hex Hd Bolt	4	LL	003002	1/8" x 2" Black Nipple	1
O	002012	5/16" Jam Nut	4	MM	004226	Air Pressure Switch	1
P	100221	Shell Subassm	1	NN	000606	1/4 x 3/4" Slotted Rd Hd Screw	1
Q	002008	1/4-20 FHN Hex Nut	1	OO	004445	Fireye Chassis	1
R	002360	Eye Bolt	1	PP	003662	Start Switch	1
S	006607	2" x 6" Burner Nozzle	1	QQ	003663	Stop Switch	1
T	003141	2" x 2 1/2" nipple	1	RR	003600	Fuse Holder	1
U	006686	2" UV Plug	1	SS	003624	5 Amp Fuse	1
V	003408	1/2" to 3/8" Fitting	1	TT	003906	Red Light	1
W	003024	1/2" TO 3/8" reducing nipple	1	UU	004300	Ignition Transformer 10000 v	1
X	004106	UV1A3 flame scanner	1	VV	003914	Step Down Transformer	1
Y	004068	7" Spark Electrode	1			(If not 115V)	
				WW	003816	Low Gas Pressure Switch	1
						Dungs# GML-A2-4-4 266942	
				XX	003780	High Gas Pressure Switch	1
						Dungs #GMH-A2-4-4 266924	
				YY	003836	Visual Indicator	2
				ZZ	004097	Plastic Extender	1
				A1	003366	3/4" Union	1
				B1	003148	2" x 6" Nipple	1
				C1	003207	2" Coupling	1
				D1	001205	3/8" x 1" hex hd bolt	2
				E1	100463	Lid Stop	1
				F1	003311	2" black tee	1
				G1	003394	2" 45 deg elbow	1

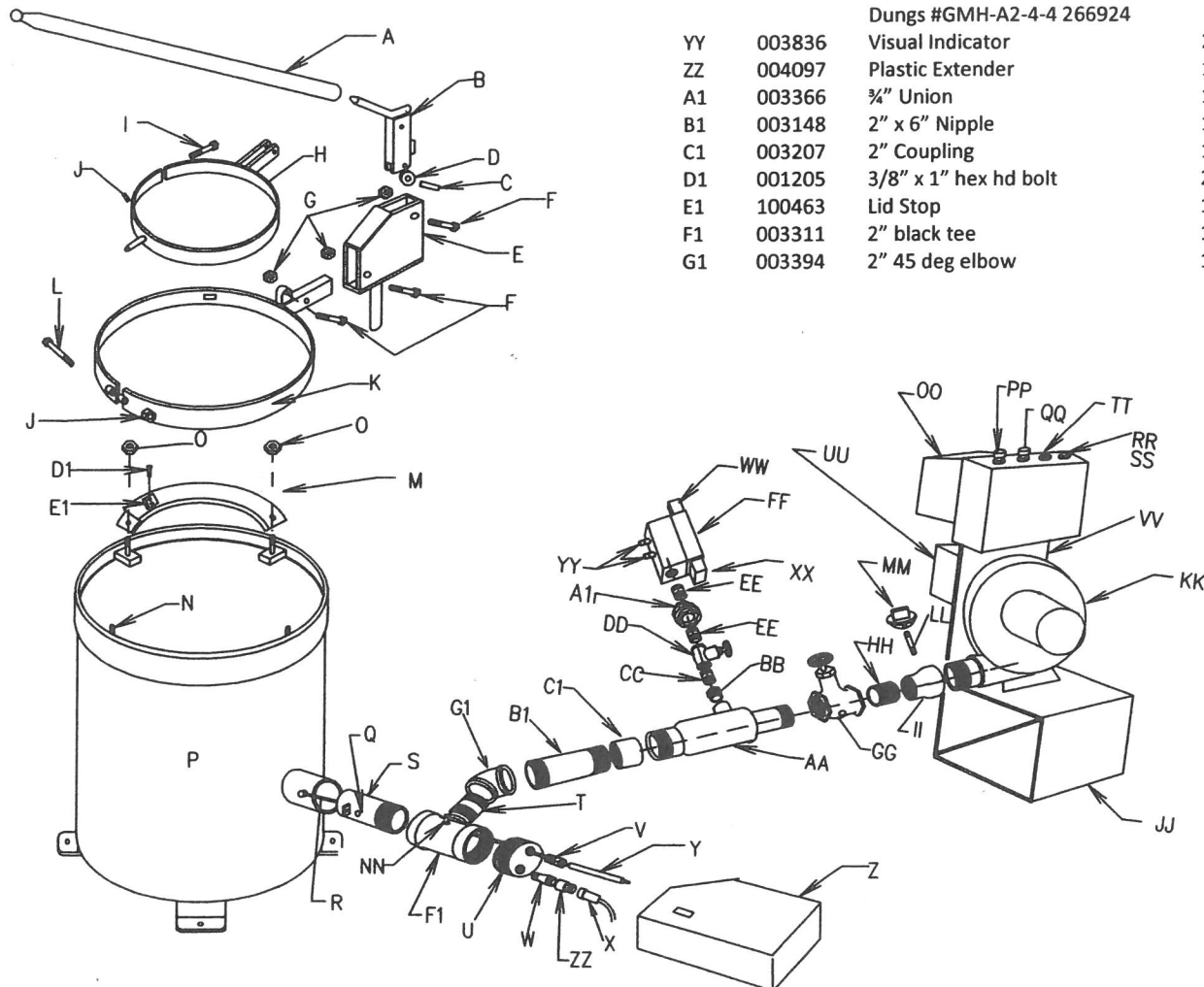

**RELINING INSTRUCTIONS FOR SPEEDY MELT
B-16, B-160 AND B-30 FURNACES** 02/2020

032007 B16, B160 Furnaces

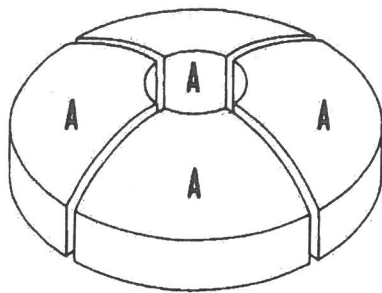

OPN	DESCRIPTION	QTY
A	008002 Lid Section	4
B	008000 Solid Side Liner	7
C	008003 Piloted Burner Brick	1
D	008004 Bottom Brick	1
	008141 Betamax 55# bag	2
	008173 Sealer 20# box	1

032008 B-30 Furnace

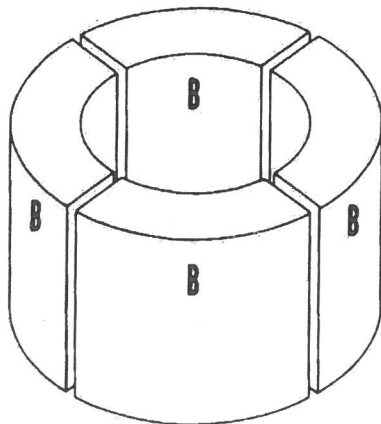

OPN	DESCRIPTION	QTY.
A	008008 Lid Section	4
B	008005 Solid Side Liner	7
C	008009 Piloted Burner Brick	1
D	008007 Bottom Brick	1
	008141 Betamax 55# bag	2
	008173 Sealer 20# box	1

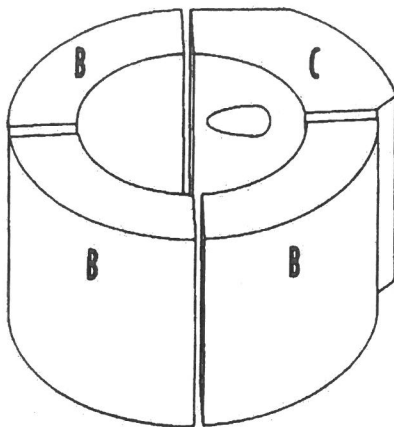

The material used in the manufacture of the lining and lid for these Speedy Melt Furnaces is High-Alumina refractory. This material is one of the best available, designed to withstand the extreme temperatures, drastic temperature changes and high velocity circulation encountered in top performing crucible melting furnaces. The fusion point of this material is near 3300F. DOMESTIC FIRE CLAY REFRACTORY, NORMALLY USED, IS ENTIRELY UNSATISFACTORY. All shapes are compressed under extreme pressures, and kiln burn. The MIFCO Furnaces have been designed so that relining is rapidly and easily done. Complete relining kits are available as a package unit. These kits include all replacement refractory shapes, insulation, and the correct type of High-Alumina refractory mortar. Structural parts of the furnaces which are subject to normal abuse and may need replacement are available. Relining procedure is as follows:

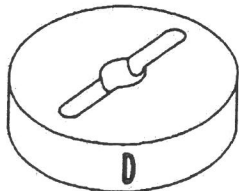

1. Remove blower and mixer-burner assembly from furnace.
2. Remove front bolt from lid band, spread lid band, remove the four lid brick sections, A.
3. Remove lid lift assembly by lifting out of the base tube. Replace lid band if damaged or burned, being careful not to lose collar bushings in jack tube. Replace both lid support rods if bent or burned.
4. Remove the four top cast iron segments by removing hex nuts on top of furnace. Remove all insulation and refractory from the furnace shell. Remove and replace seal hold down bolts if broken.

Relining Instructions for B-16, B-160 and B-30 (cont)

5. Mix part of your refractory sealer to the consistency of heavy cream for mortaring joints. With your fingers, place a ring of sealer all around the outer surface of the burner guide tube, and also some all around the inside of the burner opening in the brick. This is to prevent flame leakage.
6. Now pick up the banded group of bricks and place the burner brick over the guide tube. It should drop all the way to the bottom of the shell. Measure to make sure the bricks are centered in the shell.
7. Take a hand full or approx a cup full of mortar and dump it down in the bottom all around the center hole in the bottom of the shell. Spread out with a paint brush. Now take the bottom brick with the drain grooves up, and drop it down within the side liner. Twist the brick to spread mortar under the brick.
8. Pour a goodly amount of water all over the top of row one and let it run down the inside and outside of the bricks. Take a one pound coffee can and fill with your sealer and pour at least a $\frac{1}{4}$ " layer of sealer all around the top of row one of the liner. Next, take your second row of bricks with the smooth surface up, and set them down on top of row one, breaking the joints. Tap with a rubber mallet to make sure the bricks are seated level. Pour some more water down over the top of the second row allowing it to run down both inside and out.
9. Mix the Matrilite insulation with sufficient water to the consistency of plaster. Pour the insulation down between the inner shell and the brick lining. Either use a vibrator or a stick to prod the insulation while pouring, especially in the area of the burner. Fill the insulation up to about 1" above the top of the liner, as it will settle. With a rubber mallet tap lightly all around the shell which will also help the insulation to settle. You will notice water dripping on the floor, this is to be expected.
10. Prior to replacing your top seals, add what ever amount of insulation is required to bring it back up to about $\frac{1}{2}$ " above the brick again so when you replace the seals, the insulation will mash back down , guaranteeing a good seal. Tap lightly on each top seal as you tighten the nuts down.
11. Spread the lid band and place the four lid sections on top of the chamber lining. Align the grooves on the outside of the bricks to match the holding lugs on the inside of the band. Press down with a mallet to make sure each brick is seated on the top of your liner. Replace lid band bolt, and just snug up- do not over tighten as it will cause the brick to expand and break with heat.

12. Pull your entire lid assembly up out of the slide pipe and turn the lid upside down on the floor. Again, moisten with water and paint the under surface with sealer.
13. Now is a good time to put grease on the jack tube prior to placing it back into the slide pipe. Swing the lid to the side paint on some water on the upper surface and cover with sealer closing up any cracks between bricks.
14. With the lid open, take a wet paint brush and moisten all the liner bricks one more time, and take the balance of sealer and paint on the whole inner chamber. Also fill in around between the bottom brick and the side liner.
15. Prior to putting your burner nozzle back into the guide tube, take a flash light and make sure there is no mud blocking the inside of the burner opening, then place a light layer of sealer around the edge of your nozzle prior to putting it into the guide tube. This will insure a good seal.
16. Furnace should set for 24 hours to cure the insulation, fire at low fire for one hour to remove moisture. The following day, fire as desired. Firing at HIGH FIRE right away after insulating will cause steam to form in the bricks and blow them apart.

Included with the relining kit is a circle of 1" thick ceramic fiber blanket, the diameter of the furnace lid. Place this on top of the furnace lid for the first 2 or 3 firings/melts. After the lid bricks have been heated to a yellowish color all the way through, discard the blanket. It is provided to ensure that the lid bricks are completely cured.

032009 RELINING INSTRUCTIONS FOR B-70 SINGLE BURNER FURNACE

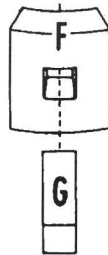
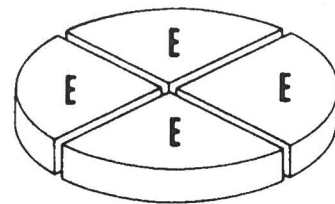
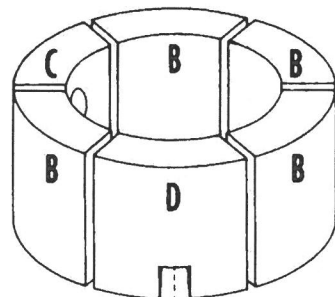
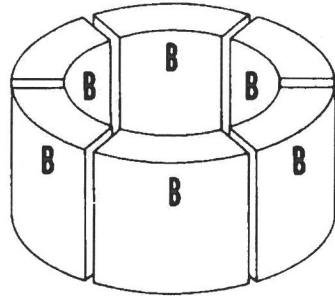
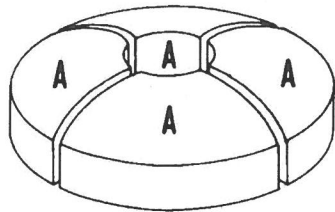

OPN	DESCRIPTION
-----	-------------

A	008022 Lid Section	4
B	008010 Solid Side Liner	10
C	008011 Piloted burner brick	1
D	008104 Drain Side liner brick	1
E	008013 Bottom brick	4
F	008103 Drain Tile	1
G	008160 Drain Tile Plug	1
	008141 Betamax 55#	

The MIFCO Furnaces have been designed so that relining is rapidly and easily done. Complete relining kits are available as a package unit. These kits include all replacement refractory shapes, insulation, and the correct type of high alumina refractory. Structural parts of the furnace which are subject to normal abuse and may need replacement, are available. Relining procedure is as follows:

1. Remove blower and mixer-burner assembly from furnace.
2. Remove front bolt from lid band, spread lid band, remove the four lid sections.
3. Remove lid lift assembly by lifting out of the base tube. Replace lid band if damaged or burned, being careful not to lose collar bushings in jack tube. Replace both lid support rods if bent or burned.

4. Remove the six top cast iron segments by removing hex nuts on top of furnace. Remove all insulation and refractory from furnace shell. Remove and replace seal hold down bolts if broken. Remove burner guide tube.

5. Mix part of refractory sealer to consistency of heavy cream for mortaring joints.

6. Place four segments of Bottom Bricks **E** in center of furnace chamber. Measure side clearance between brick and shell to locate bottom correctly. Wet brick surfaces to be mortared, with water. This improves mortar joints. Dry bricks absorb moisture from mortar too rapidly resulting in weak joints. Use brush or sponge to saturate surfaces with water.

7. Set banded burner ring in place, lining up the burner hole with the burner guide tube when they are in place. **DO NOT REMOVE THESE BANDS.** This burner ring should be cemented in place by pouring a ring of cement where the bottom row of bricks are to set. Be sure to wet the mating surfaces before applying mortar. Put mortar inside of burner hole, insert burner guide tube, and bolt into place. Wipe excess mortar from inside of burner tunnel.

Relining Instructions for B-70 - (cont.)

8. Mortar drain tile **F** in place and line up drain hole by inserting drain tile plug **G**.
9. Mix patching plastic per instructions on container and build up all around the burner guide tube. This build up should be about 1" thick and next to the burner brick **C**, there should be a heavy fillet working the castable well against the brick to assure a good bond.
10. Cement second ring of six solid liner bricks **B** in place. Put the smooth side up to mate with the lid. If the bricks are loose, turn the smooth side down on a flat surface and make wooden wedges to drive between the bands and the bricks. This will tighten the bands. **DO NOT OVER-TIGHTEN**. Over-tightening will cause the bricks to crack when they expand from heating. Wet the bottom of this row and the top of the bottom row well and then pour a ring of cement on the top of the bottom row. Lower the top row of bricks in place and revolve ring of bricks to get the cement thinned out and seat the bricks. The vertical joints should be staggered.
11. Mix pre-mixed insulation with sufficient water to the consistency of plaster. Pour insulation between shell and refractory lining. Prod while pouring to form even distribution of insulation. Fill to height of liners, wait approximately 30 minutes and fill to top again.
12. Replace top seal segments and bolt down in place. Replace lid lift assembly after applying thin layer of grease to tube.
13. Spread lid band and place four lid segments **A** on top of furnace chamber lining. Align the grooves on the outside of the lid bricks to match the holding lugs in the lid band. Press or tap each top segment down to seat against the chamber lining. Replace the front lid band bolt and tighten snug. **DO NOT OVER-TIGHTEN**.
14. Apply small amount of refractory sealer to burner nozzle and reassemble. Be sure burner enters to refractory stop. Thin mortar with water to consistency of a paint and paint all exposed brick surfaces.
15. Furnace should set for 24 hours to cure insulation, then fire at low fire for one hour to remove moisture. The following day, fire as desired. Firing at HIGH-FIRE right away will cause steam to form in the bricks and blow them apart.

RELINING INSTRUCTIONS FOR SPEEDY-MELT MODEL B-301 FURNACE 2/2020

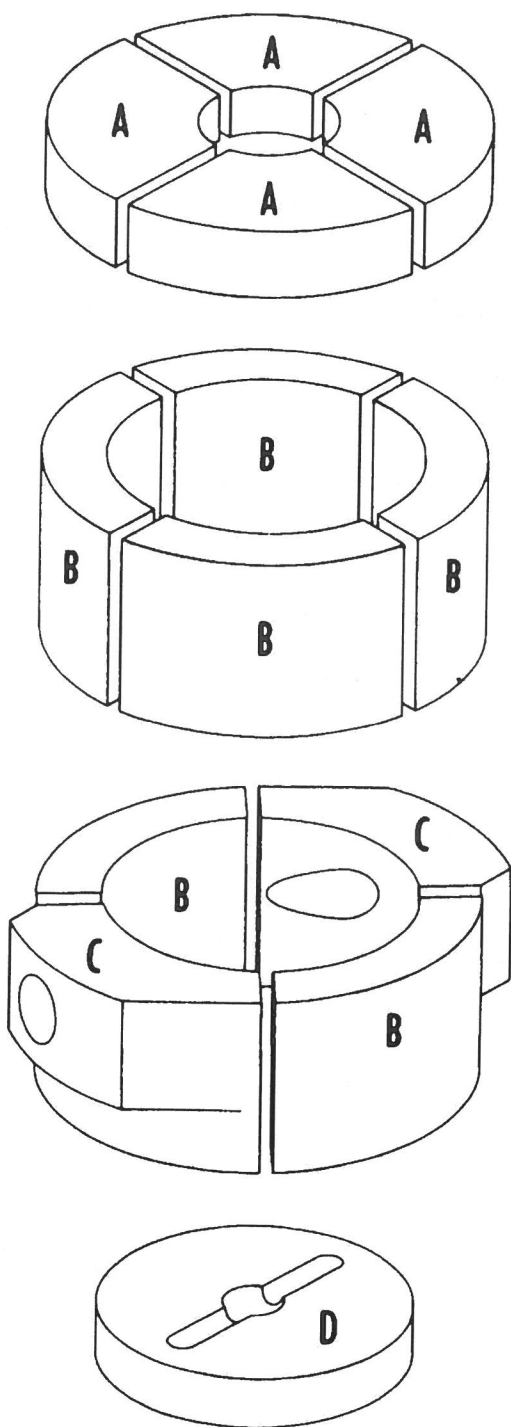

OPN	DESCRIPTION	QTY.
A 008008	Lid Section	4
B 008005	Solid Side Liner	6
C 008009	Piloted burner	2
D 008007	Bottom Brick	1
008141	Betamax-55#	2
008173	Sealer-20#	1

The MIFCO Furnaces have been designed so that relining is rapidly and easily done. Complete relining kits are available as a package unit. These kits include all replacement refractory shapes, insulation, and the correct type of High Alumina refractory. Structural parts of the furnace which are subject to normal abuse, and may need replacement, are available. Relining procedure is as follows:

1. Remove blower, gas-air mixer assembly, ignition and combustion safeguard system from manifold. Disassemble manifold and unbolt burner guide tubes from furnace shell.
2. Remove front bolt from lid band, spread lid band and remove the four lid brick sections,
3. Remove lid lift assembly by lifting out of the base tube. Replace lid band if damaged or burned, being careful not to lose collar bushings in jack tube. Replace both lid support rods if bent or burned.
4. Remove the four top cast iron segments by removing hex nuts on top of furnace. Remove all insulation and refractory from furnace shell. Remove and replace seal hold down bolts if broken. Remove burner guide tubes.

5 Mix part of refractory sealer to consistency of heavy cream for mortaring joints. Wet the brick surfaces to be mortared with water to improve mortar joints. Dry bricks absorb moisture from mortar too rapidly, which results in weak joints. Use brush or sponge to saturate brick surfaces with water.

6 Locate the bottom row of two burner bricks **C** and two solid side liners **B** to match up with burner guide tubes. If bands are loose, turn the row upside down on flat surface and drive wooden wedges between straps and bricks to tighten up the bands. **DO NOT REMOVE BANDS.** Line the hole in the brick where the burner guide tube goes with mortar and insert the burner guide tube. Do this to the other side and then tighten all four bolts on the burner guide tubes. **DO NOT OVERTIGHTEN.**

Relining Instructions for a B-301 - (cont.)

7. Cement the bottom brick "D" in place with the drain grooves up.
8. Cement the second row of four solid side liners "B" in place and stagger the joints so that they don't line up with the bottom row. Also, **DO NOT BREAK THE BANDS**. If they are loose, put the smooth side of the bricks down on the floor or flat surface and tighten bands with wedges of wood driven between bands and bricks. **DO NOT OVER TIGHTEN**. Wet the joints between the top and bottom rows and then, pour a row of mortar on top of the bottom row. Next sit the top row in place, moving it around a little to line up sides and flatten out mortar. Be sure you cement the top row with the smooth side up.
9. Mix pre-mixed insulation with sufficient water to the consistency of plaster. Pour the mixed insulation between the furnace shell and the brick lining. Prod while pouring to assure even distribution of insulation. Fill to the height of the furnace shell. Wait approximately 30 minutes and finish filling.
10. Replace top seal segments and bolt down in place. Replace lid lift assembly after applying thin layer of grease to inside lifting tube.
11. Spread lid band and place four lid segment sections "A" on top of furnace chamber lining. Align the grooves in the outside of the lid bricks to match the holding lugs in the lid band. Press or tap each top segment down to seat against chamber lining. Replace the front lid band bolt and tighten snug. **DO NOT OVER TIGHTEN. OVERTIGHTENING WILL CAUSE THE LID BRICKS TO CRACK WHEN THEY EXPAND FROM HEATING.**
12. Apply a small amount of refractory cement to the outside of the main burner tips and re-assemble burner manifold. Thin the mortar with water to the consistency of paint and cover all exposed brick surfaces. As explained above, wet the brick surfaces before coating.
13. Re-connect blower, gas-air mixer unit, ignition and combustion safeguard leads to furnace body.
14. Furnace should set for 24 hours to cure insulation, then fire at low fire for one hour to remove moisture. The following day, fire as desired. Firing at **HIGH-FIRE** right away will cause steam to form in the bricks and blow them apart. The furnace will emit steam and water from the lining when first fired. This is normal until the furnace is completely dry.

Included with your relining kit is a circle of 1" thick ceramic fiber blanket, the diameter of the furnace lid. Place this on top of the furnace lid for the first 2 or 3 firings/melts. After the lid bricks have been heated to a yellowish color, all the way through, this blanket can be discarded. It is provided to insure that the lid bricks are completely cured.

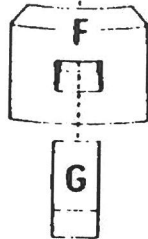
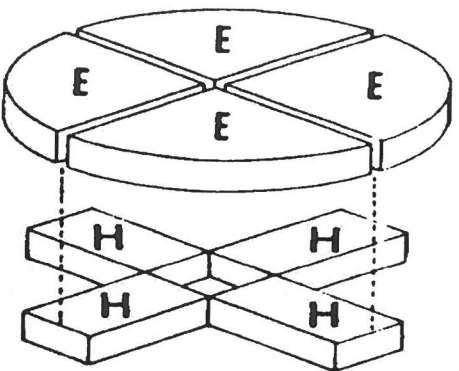
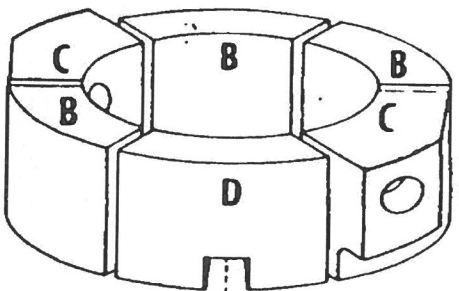
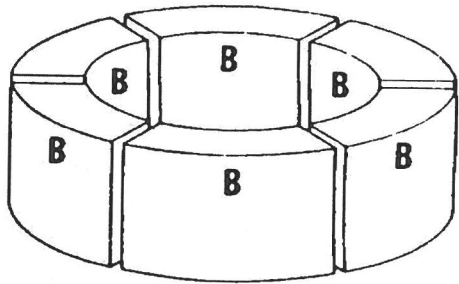
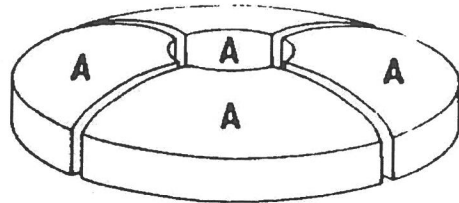

OPN	DESCRIPTION	QTY.
A 008022	Lid Section	4
B 008010	Solid Side Liner	9
C 008011	Piloted Burner	2
D 008104	Drain Side Liner	1
E 008013	Bottom Brick	4
F 008103	Drain Tile	1
G 008160	Drain Tile Plug	1
H 008162	Bottom Support Brick	4
008141	Betamax Insulation-55#	6
008173	Refractory sealer -2 boxes	

The MIFCO Furnaces have been designed so that relining is rapidly and easily done. Complete relining kits are available as a package unit. These kits include all replacement refractory shapes, insulation, and the correct type of High-Alumina refractory. Structural parts of the furnace which are subject to normal abuse and may need replacement are available. Relining procedure is as follows:

1. Remove blower, gas-air mixer assembly, ignition and combustion safeguard system from manifold. Dis-assemble manifold and unbolt burner guide tubes from furnace shell.
2. Remove front bolt from lid band, spread lid band, remove the four lid brick sections A.
3. Remove lid lift assembly by lifting out of the base tube. Replace lid band if damaged or burned, being careful not to lose collar bushings in jack tube. Replace both lid support rods if bent or burned.
4. Remove the six top cast iron segments by removing hex nuts on top of furnace. Remove all insulation and refractory from furnace shell. Remove and replace seal hold down bolts if broken.

Relining Instructions for a B-702 - (cont.)

5. In a flat bottom pan, mix part of your refractory sealer to a consistency that will spread but not run. Locate the 4 bricks letter (H), and dip them in to a pan or bucket of water. Then, just dip the flat bottom of each brick into the sealer. Locate them in the bottom of the shell as shown.
6. Now locate a couple bags of Matrilite 2800 and mix according to the instructions. The consistency should be of flowing plaster. Trowel in and around the bricks, letter (H). Fill to the top of the bricks and strike off flush. Let set 24 hours. Proceed with the bottom row, letter (E). Do not cut the bands. Place the four seams on top of the letter (H) bricks.
7. Locate the burner row of bricks down over the bottom, aligning the burner holes with the holes in the side of the shell. The drain brick (D) should line up with the hole in the center of the shell. Place a thin layer of sealer around the front edge of the burner guide tube and place the tube through the hole in the shell until it touches the ledge on the inside of the burner brick. Tighten the bolts.
8. Mortar Drain Tile, (F), in alignment with the drain hole. Insert Drain Tile Plug, (G), in place to complete bottom ring.
9. Saturate matching surfaces of top and bottom rings with water to prevent rapid drying of mortar. Place a layer, of mortar on top surface of the bottom ring of bricks, already located in the furnace. Next, lower the banded top ring of solid side-liners, (B), into position over the bottom ring, flat side up. Rotate top ring to get a tight mortar joint, making sure to stagger brick joints in top and bottom rows. Level top surface of second ring with top of furnace so lid will seat properly.
10. Mix the remainder of insulation with sufficient water to the consistency of plaster. Pour the insulation between the furnace shell and the brick lining. Prod while pouring to assure an even distribution. Fill to the height of the furnace shell, wait approximately 30 minutes and finish filling.
11. Replace top seal segments and bolt down in place. Replace lid lift assembly after applying thin layer of grease to tube.
12. Spread lid band and place four Lid Segment Sections, (A), on top of furnace chamber lining. Align the grooves in the outside of the lid bricks to match the holding lugs in the lid band. Press or tap each top segment down to seat against chamber lining. Replace the front lid band bolt and tighten snug. **DO NOT OVER TIGHTEN. OVER-TIGHTENING WILL CAUSE THE LID BRICKS TO CRACK WHEN THEY EXPAND FROM HEATING.** Swing lid to side and coat upper and lower surfaces with sealer.
13. Apply a small amount of refractory cement to the outside of the burner nozzles and re-assemble burner manifold. Thin the mortar with water to the consistency of heavy paint and cover all exposed brick surfaces. As explained above, wet the brick surfaces before coating.
14. Re-connect blower, gas-air mixer unit, ignition and combustion safeguard leads to furnace body. Furnace should set for 24 hours to cure insulation, then fire at low-fire for one hour to remove moisture. The following day, fire as desired. Firing at HIGH-FIRE right away will cause steam to form in the bricks and blow them apart. The furnace will emit steam and water from the lining when first fired. This is normal until the furnace is completely dry. Place enclosed circle of fiber blanket onto the lid for first melt. You can then keep or discard the fiber blanket.

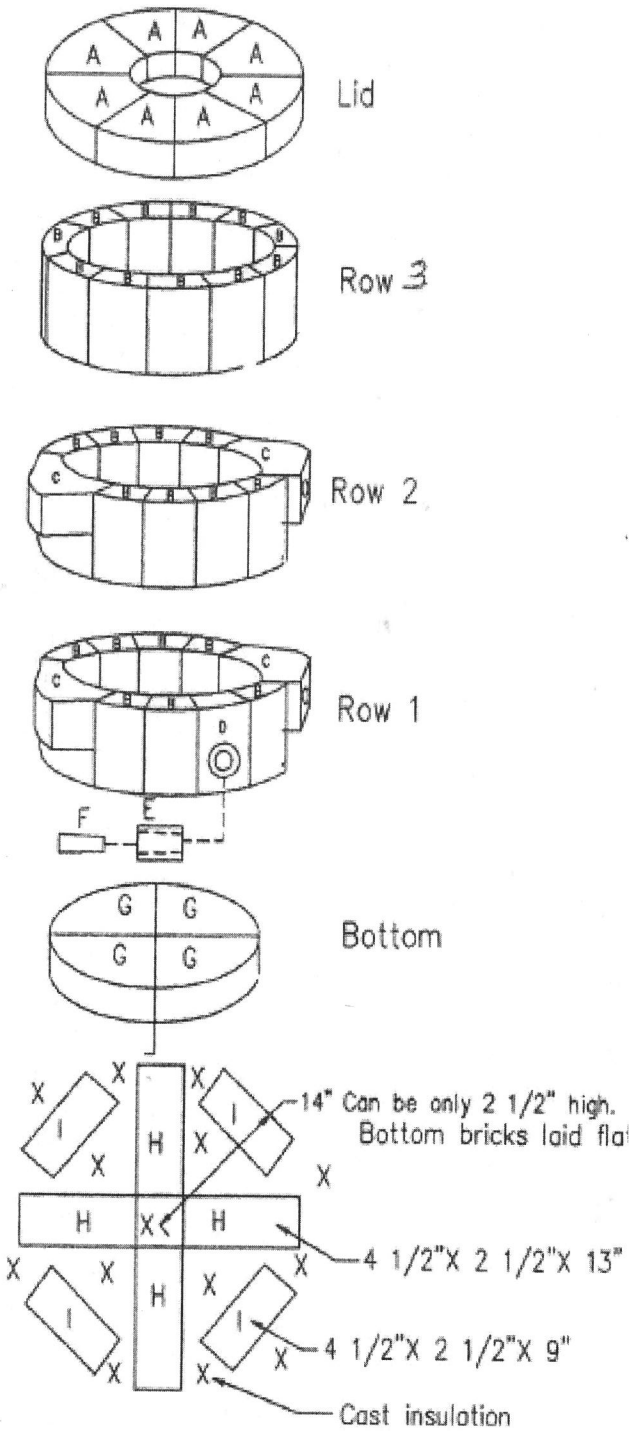

OPN	DESCRIPTION	QTY.
A	008089 Lid Section	8
B	008087 Solid Side Liner	26
C	008090 Burner Liner	4
D	008093 Side Drain Liner.	1
E	008092 Drain Tile	1
F	008088 Drain Tile Plug	1
G	008096 Bottom Brick	4
H	008164 Bottom Support 13 1/2"	4
I	008162 Bottom Support 9"	4
	Betamax Insulation 55#	12
	Refractory Sealer 55#	1

The MIFCO Furnaces have been designed so that relining is rapidly and easily done. Complete relining kits are available as a package unit. These kits include all replacement refractory shapes, insulation and the correct type of High Alumina refractory. Structural parts of the furnace which are subject to normal abuse, and may need replacement, are available. Relining procedure is as follows:

1. Remove blower and mixer / burner assembly from furnace by disconnecting the pipe union at the manifold and the spark ignition and ultra violet scanner leads to the burner tee fitting. Scanner leads and spark ignition lead wires are with furnaces with safety systems.
2. Disconnect manifold union and remove the manifold and burners from furnace body.
3. Remove burner guide tubes from burner shell.
4. Remove the front clamp bolt from the lid band, spread the lid band, and remove the eight lid sections, (A).
5. Remove lid lift assembly by lifting out of the base tube. Replace lid band if damaged or burned. Replace both lid support rods if bent or burned.

Relining Instructions for B-1501 - (cont.)

6. Remove the six top iron segments by removing the hex nuts on furnace top. Remove all insulation and refractory from furnace shell. Replace seal hold down bolts if broken.
7. The three rows of bricks come banded together in rows. **DO NOT REMOVE THESE BANDS.** If the bricks are loose, place on flat surface with top side down and drive a wooden wedge between the band and the bricks. This will tighten the bands. **DO NOT OVERTIGHTEN.**
8. Remove the burner guide tube from the furnace shell.
9. Locate the 8 insulating support bricks "H" and "I". Soak each brick in water and place in bottom of the furnace shell in pattern shown. The bricks should all be level 2 1/2" high.
10. Mix enough insulation material to cover the bottom of the furnace in between the insulating bricks (H) & "I". Add enough water to the insulation until it is just wet enough to pour-1 gal per 25 lbs. Strike off level.
11. Locate the Bottom Row of bricks, made up of Burner Liner (C), Solid Side Liners (B), and Side Drain Liner (D), on top of the insulating support bricks, and align the burner holes with the burner guide tubes. Put some mortar in the burner holes of the brick and bolt the burner guide tube in place. Clean the excess from the inside of the burner guide tube holes. Mortar Drain Tile (E) in place with the SMALL end in first. Insert Drain Tile Plug (F) in drain tile hole to help hold tile in place.
12. Mix the refractory mortar with water to consistency of paste. **DO NOT USE INSULATING CEMENT. USE THE REFRACTORY SEALER TO MORTAR BRICKS TOGETHER.**
13. The four bottom bricks "G" are now ready to put in place. These sections sit right on top of the insulating support bricks "H" and "I" and the insulation.
14. The center row is to be placed in position next. **DO NOT REMOVE THE BANDS.** Wet the top of row one and the bottom of row two with water and then pour a ring of sealer on top of row one. Lower the second row in place, aligning the burner holes, also moving the row of bricks so you will get a tight bond between the rows. The burner guide tubes should now be put in place following the same procedure before. It would be advisable to put in the burner assembly before tightening the burner guide tube bolts.
15. Repeat the above step for top Row 3. Mix the balance of the insulation aggregate, the same as before. Finish filling the cavity between the shell and furnace lining. Fill to the top of the furnace shell.
16. Tap the furnace shell to help make the insulation settle. Allow approximately 30 minutes for the insulation to settle, then add enough insulation to top off.
17. Replace sectional cast iron ring plates and secure with bolts.

Relining Instructions for B-1501 - (cont.)

18. Apply a layer of grease to lid lift tube and replace the lid lift assembly in the lower guide tube. Grease the lid lift unit through the grease fitting.
19. Spread the lid lift brick ring and replace the Lid Bricks (A). Align the slots in the lid bricks to match the brick keys in the lid ring. Replace the lid band bolt and tighten bolt until just snug. Tap the lid band with a mallet or wooden bar. Lid sections will shift slightly and allow for re-tightening of the lid band bolt. Continue this procedure until all bricks have been aligned and the ring is tight, then loosen nut about one turn. **OVERTIGHTENING WILL CAUSE THE LID BRICKS TO CRACK WHEN THEY START TO EXPAND FROM HEATING.**
20. Add some water to the refractory sealer until you are able to brush it on. **DO NOT GET IT TOO THIN OR THE BINDER IN THE SEALER WILL BE SO DILUTED THAT THE COATING WILL JUST BRUSH OFF WHEN IT DRIES.** Brush on a coating of water to get the brick surfaces and all joints soaked . Brush on the sealer coating to all brick surfaces and work into all cracks. Be sure to do the bottom and top of the lid.
21. The furnace should set at least 24 hours to allow the insulation to set up and cure. After this period of time, the furnace can be fired slowly to drive off all moisture and water vapor from the insulation and lining. The following day, fire as desired. Firing at **HIGH-FIRE** right away will cause steam to form in the bricks and blow them apart. The furnace will emit steam and water from the lining when first fired. This is normal until the furnace is completely dry.

HIGH SPEED MELTER MODEL B-160

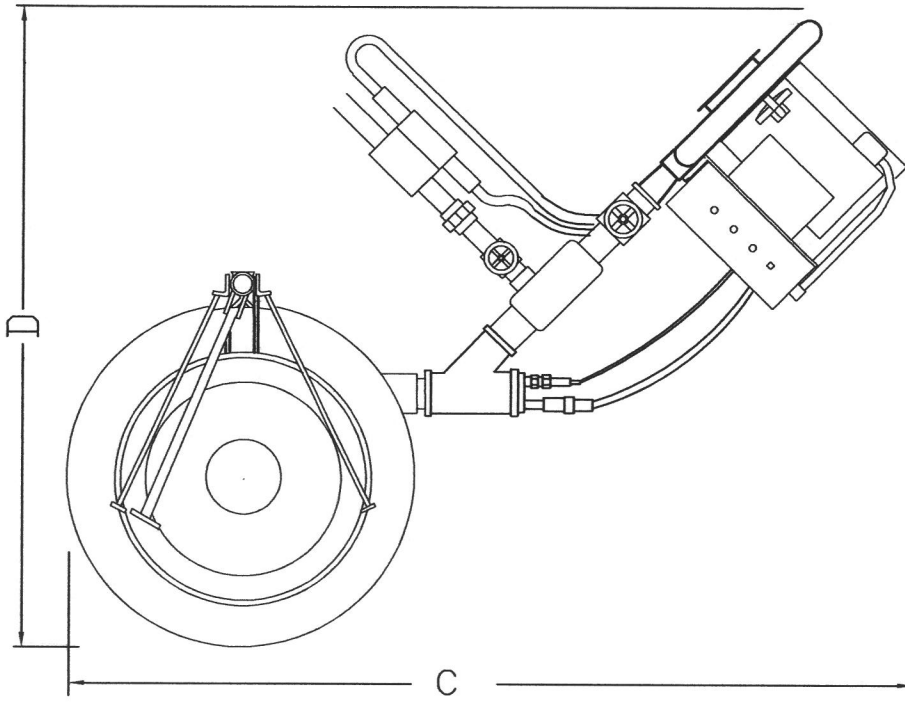

Model	Dia.	Depth	A	B	C	D	E
B160	10"	12"	20"	31"	57"	50"	21.5"

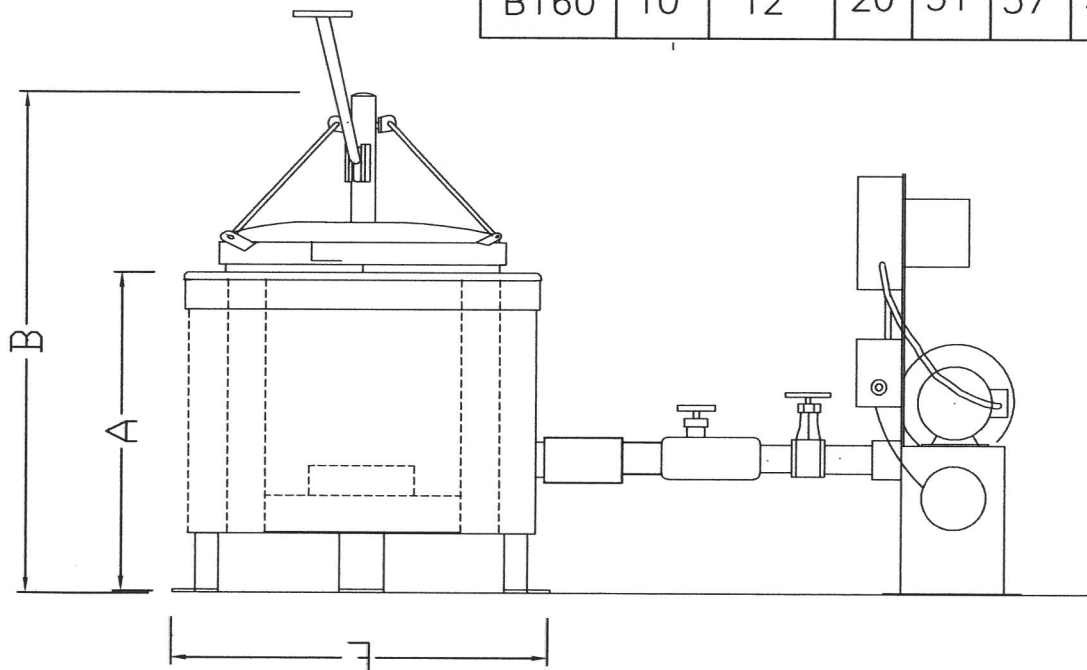

McEnglevar Ind. Furnace Mfg. Co. Inc.
Danville Il. 61832
Dim.View 12/19

MELTERS\B160\100702-A

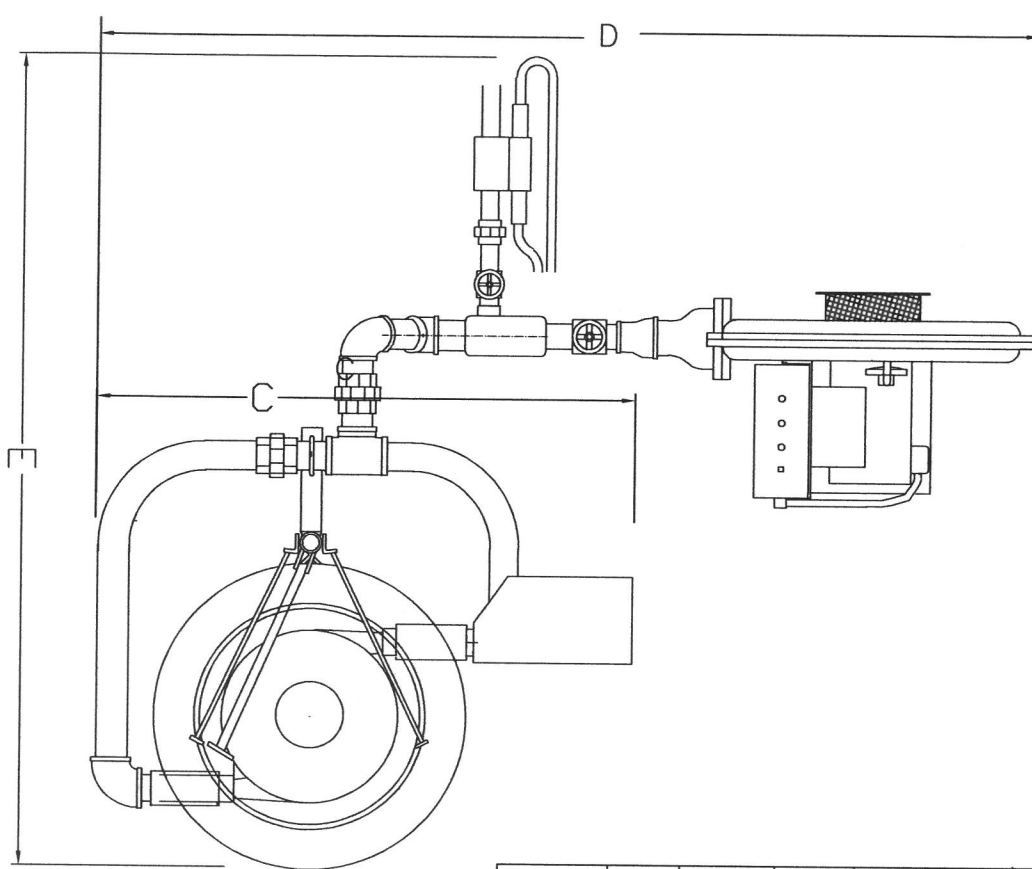

Model	Dia.	Depth	A	B	C	D	E	F
B301	13"	15"	23"	34"	39"	76"	66"	24.5"
B702	17"	20"	28"	43"	47"	79"	68"	32.5"
B1501	21"	24"	34"	51"	61"	90"	80"	40"
B2001	23"	25"	36"	53"	63"	94"	80"	40"

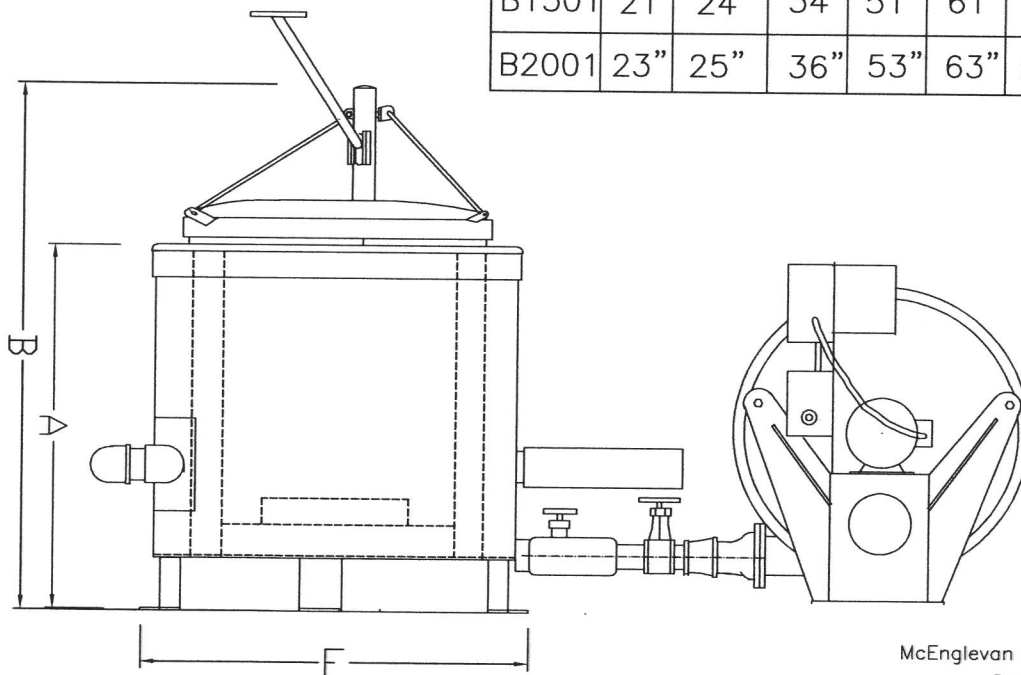

McEnglevan Ind. Furnace Mfg. Co. Inc.
Danville Il. 61832

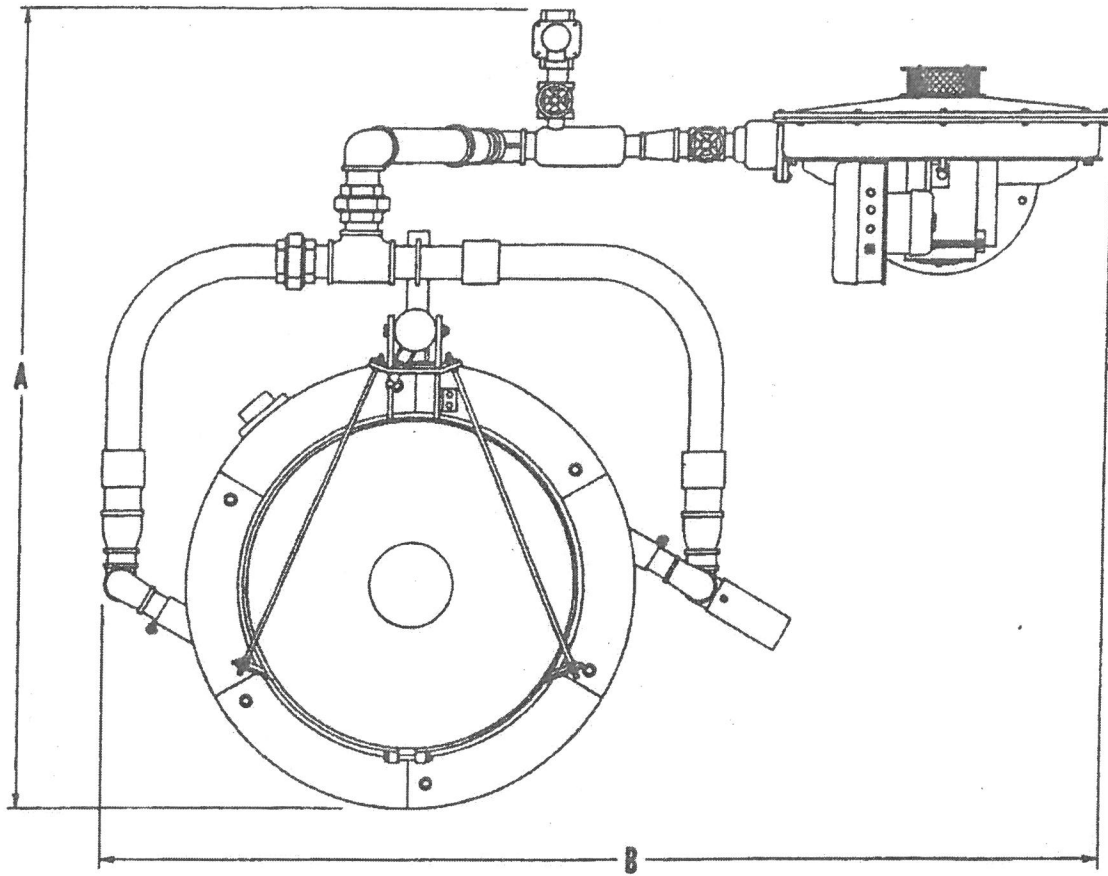

PRIOR TO YEAR 2015

**SPEEDY-MELT
HIGH SPEED MELTER
Models B-1501**

MODEL	COMBUSTION CHAMBER		FLOOR INSTALLATION				
	DIA.	DEPTH	A	B	C	D	E
B-1501	21"	24"	66"	83"	51"	35"	38"

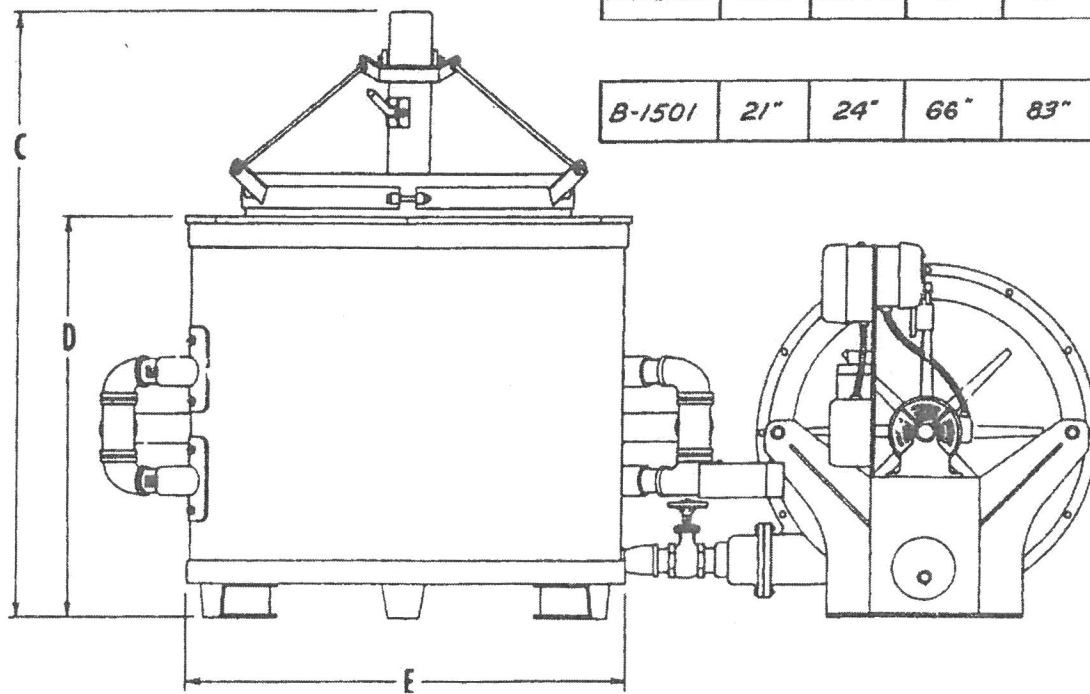

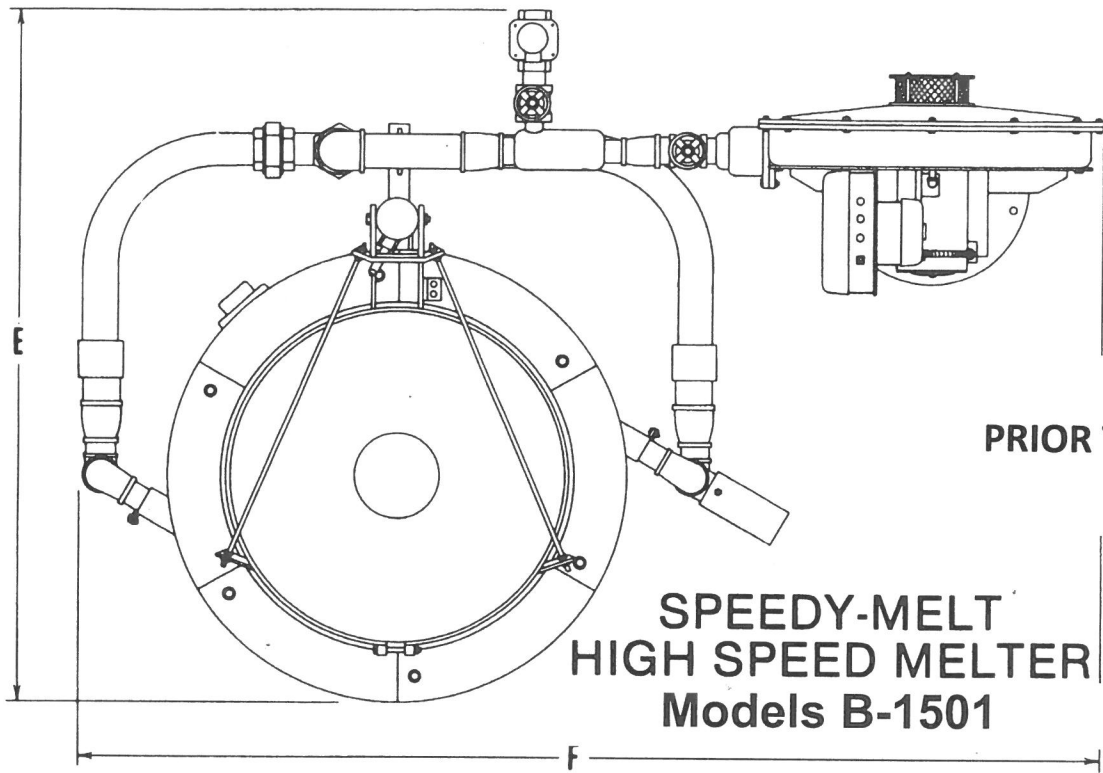

MODEL	COMBUSTION CHAMBER		PIT TYPE INSTALLATION							
	DIA.	DEPTH	A	B	C	D	E	F	G	H
B-1501	21"	24"	38"	35"	51"	58"	57"	85"	59"	23"

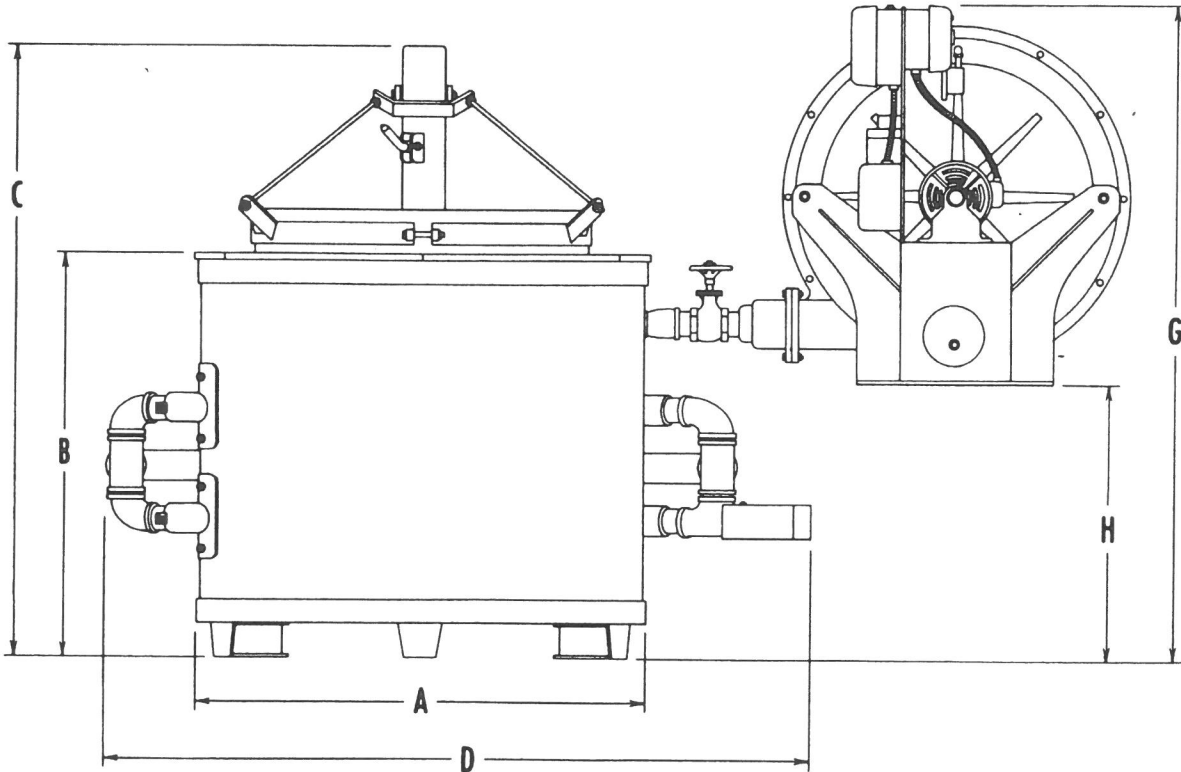

B-160

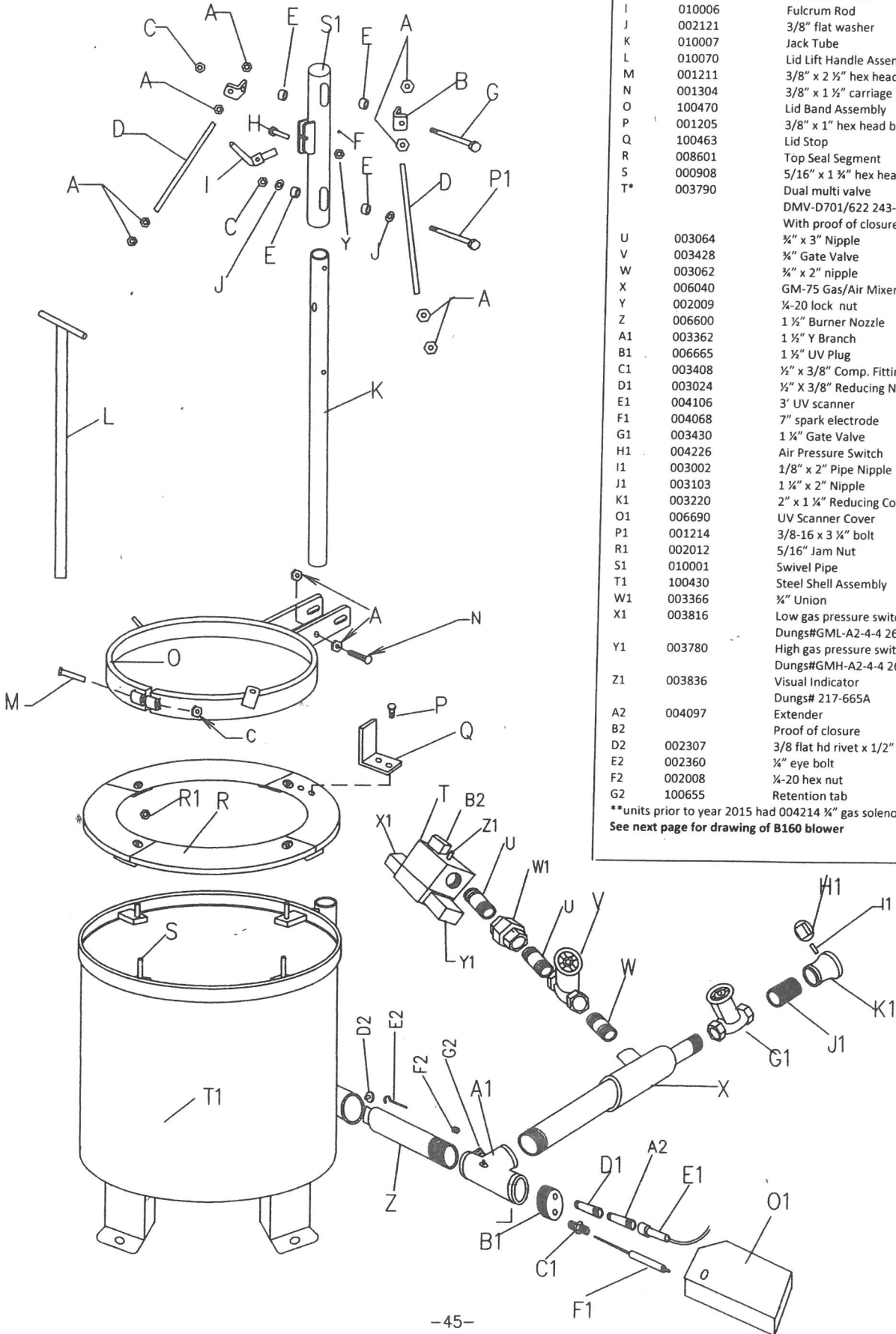

06/21	OPN	DESCRIPTION	QTY
A	002016	3/8" Jam Nut	10
B	010008	Support Rod Bracket	2
C	002017	3/8" Hex Lock Nut	3
D	100475	Lid Support Rod	2
E	010009	Lid Lift Bushings	4
F	010005	Drive In Grease Fitting	1
G	001213	3/8" x 3" Hex Head Bolt	1
H	000711	1/4-20 x 1 1/4" bolt	1
I	010006	Fulcrum Rod	1
J	002121	3/8" flat washer	2
K	010007	Jack Tube	1
L	010070	Lid Lift Handle Assembly	1
M	001211	3/8" x 2 1/2" hex head bolt	1
N	001304	3/8" x 1 1/2" carriage bolt	1
O	100470	Lid Band Assembly	1
P	001205	3/8" x 1" hex head bolt	2
Q	100463	Lid Stop	1
R	008601	Top Seal Segment	4
S	000908	5/16" x 1 1/4" hex head bolt	4
T*	003790	Dual multi valve Dungs# DMV-D701/622 243-761P With proof of closure	1
U	003064	1/4" x 3" Nipple	2
V	003428	1/4" Gate Valve	1
W	003062	1/4" x 2" nipple	1
X	006040	GM-75 Gas/Air Mixer	1
Y	002009	1/4-20 lock nut	1
Z	006600	1 1/2" Burner Nozzle	1
A1	003362	1 1/2" Y Branch	1
B1	006665	1 1/2" UV Plug	1
C1	003408	1/2" x 3/8" Comp. Fitting	1
D1	003024	1/2" x 3/8" Reducing Nipple	1
E1	004106	3" UV scanner	1
F1	004068	7" spark electrode	1
G1	003430	1 1/4" Gate Valve	1
H1	004226	Air Pressure Switch	1
I1	003002	1/8" x 2" Pipe Nipple	1
J1	003103	1 1/4" x 2" Nipple	1
K1	003220	2" x 1 1/4" Reducing Coupling	1
O1	006690	UV Scanner Cover	1
P1	001214	3/8-16 x 3 1/4" bolt	1
R1	002012	5/16" Jam Nut	4
S1	010001	Swivel Pipe	1
T1	100430	Steel Shell Assembly	1
W1	003366	1/4" Union	1
X1	003816	Low gas pressure switch Dungs#GML-A2-4-4 266942	1
Y1	003780	High gas pressure switch Dungs#GMH-A2-4-4 266924	1
Z1	003836	Visual Indicator Dungs# 217-665A	1
A2	004097	Extender	1
B2		Proof of closure	1
D2	002307	3/8 flat hd rivet x 1/2" lg	1
E2	002360	1/4" eye bolt	1
F2	002008	1/4-20 hex nut	1
G2	100655	Retention tab	1

**units prior to year 2015 had 004214 1/4" gas solenoid
See next page for drawing of B160 blower

1175 BLOWER ASSEMBLY FOR B 160

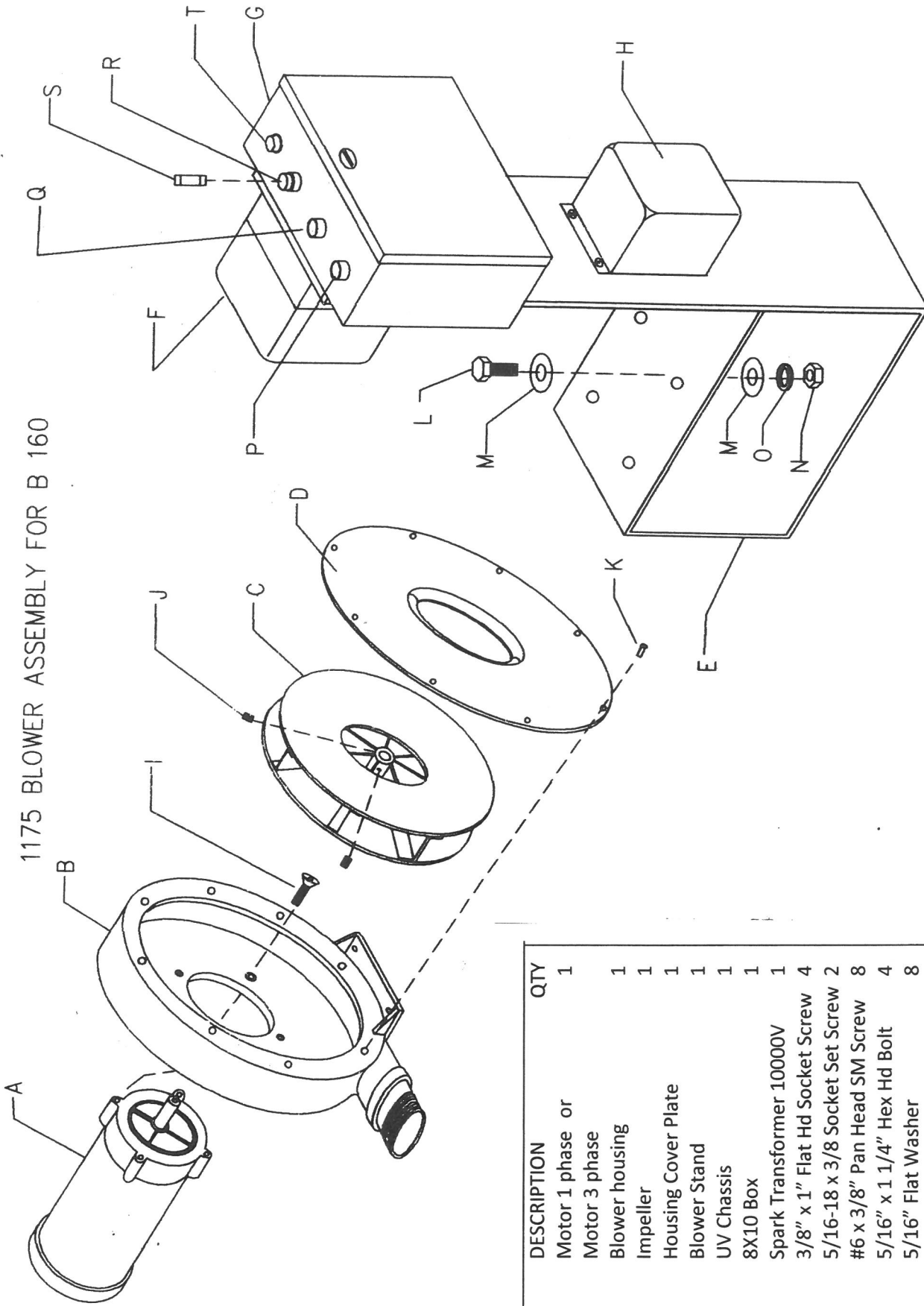

OPN	DESCRIPTION	QTY
004117	Motor 1 phase or	1
004118	Motor 3 phase	1
008612	Blower housing	1
004326	Impeller	1
008621	Housing Cover Plate	1
006210	Blower Stand	1
004445	UV Chassis	1
003852	8X10 Box	1
004300	Spark Transformer 10000V	1
001254	3/8" x 1" Flat Hd Socket Screw	4
001053	5/16-18 x 3/8 Socket Set Screw	2
000107	#6 x 3/8" Pan Head SM Screw	8
000930	5/16" x 1 1/4" Hex Hd Bolt	4
002115	5/16" Flat Washer	8
002011	5/16" Hex Nut	4
002116	5/16" Lock Washer	4
003663	Red Stop Button	1
003662	Black Start Button	1
003600	Fuse Holder	1
003624	5 Amp Fuse	1
003906	Red Indicator Light	1

B301

See Page 48 and 49 for parts list

!!/23

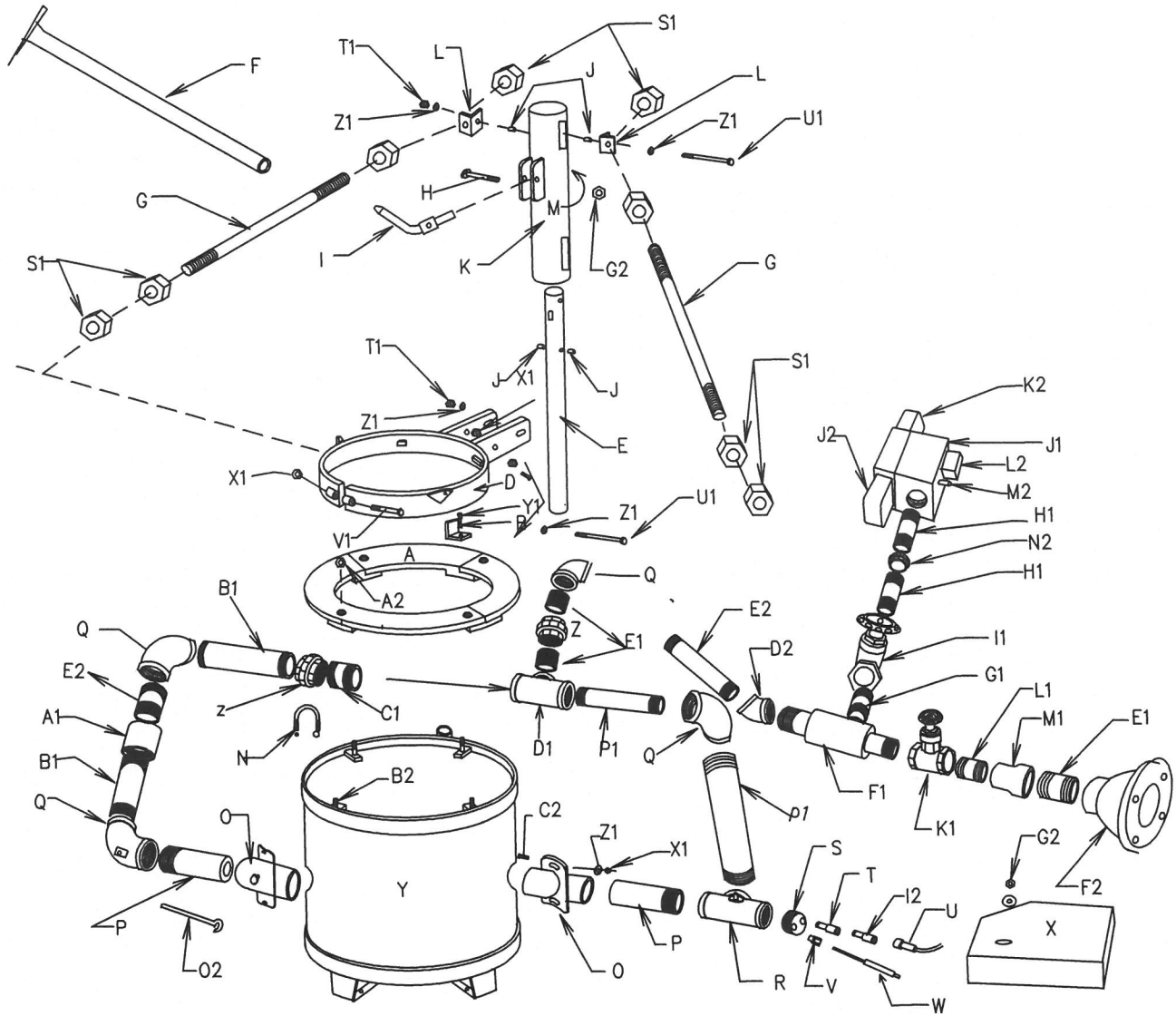

McEnglevan Parts List B-301 (11/28/2023)

A	008602	Top Seal Segment	4	H1	003088	1" x 3" Nipple	2
B	100463	Lid Band Stop	1	I1	003429	1" Gate Valve	1
C				J1	003790	Dual Valve	1
D	100660	Lid Band Assembly	1			Dungs#DMV-D 701/622	
E	010007	Jack Tube	1			243-761	
F	010070	Lid Lift Handle	1	K1	003431	1 1/2" Gate Valve	1
G	100476	Support Rod	2	L1	003107	1 1/2" x 2" Nipple	1
H	000711	1/4 -20 x 1 3/4 bolt	1	M1	003224	2" x 1 1/2" Red.Coupling	1
I	010006	Lid Lift Fulcrum	1	P1	003151	2" x 8" nipple	2
J	010009	Lid Lift Bushings	4	S1	002016	3/8" Hex Jam Nut	8
K	010001	Swivel Pipe	1	T1	002017	3/8" Hex Lock Nut	2
L	010008	Support Rod Brackets	2	U1	001213	3/8" x 3" Hex Hd Bolt	2
M	010005	Drive in Grease Fitting	1	V1	001211	3/8" x 2 1/2" HxHd Bolt	1
N	000986	3/8" x 2" ubolt	1	W1	001304	3/8" x 1 1/2" Carriage Blt	1
O	100673	Burner Guide Tube	2	X1	002015	3/8" Hex Nut	8
P	006608	Burner Nozzle	2	Y1	001205	3/8" x 1" Hex Hd Bolt	2
Q	003379	2" Elbow 90 deg.	3	Z1	002121	3/8" Flat Washer	7
R	003309	2" UV Tee Assembly	1	A2	002012	5/16" Jam nut	4
S	006686	2" UV Plug	1	B2	000908	5/16" x 1 3/4" Hx Bolt	4
T	003024	1/2" x 3/8" Red.Nipple	1	C2	001305	3/8" x 1" Carriage Bolt	4
U	004107	6'UV Scanner	1	D2	003394	2" 45 deg Elbow	1
V	003408	1/2" x 3/8" Comp.Fitting	1	E2	003146	2" x 5" Nipple	2
W	004068	7" Ignition Electrode	1	F2	008616	Blower Flange	1
X	006690	UV Scanner Cover	1	G2	002009	1/4-20 Locknut	1
Y	100620	Steel Shell Assembly	1	H2			
Z	003370	2" std union	2	I2	004097	Extender	1
A1	003207	2" Pipe Coupling	1	J2	003780	High Press.Gas Switch	1
B1	003155	2" x 12" Nipple	2			Dungs# GMH-A2-4-4	
C1	003142	2" x 3" Nipple	1	K2	003816	Low Press.Gas Switch	1
D1	003311	2" Tee	1			Dungs# GML-A2-4-4	
E1	003141	2" x 2 1/2" Nipple	3	L2	003836	Visual Indicator	1
F1	006060	GM100 Gas/Air Mixer	1	M2		Proof of Closure	1
G1	003086	1" x 2" Nipple	1			(part of Dual Valve)	
				N2	003367	1" Blk Union	1
				O2	002360	Eyebolt	2

1610 BLOWER ASSM FOR B-301 09/2022

OPN	DESCRIPTION	QTY	Part
A	Intake Guard	1	O
B	Intake Screen	1	P
C	Blower Cover	1	Q
D	Impeller Assembly 15"	1	R
E	Foam Insulation Strip	1	S
F	Blower Housing	1	T
G	004124 1HP 1ph motor	1	U
H	004123 1HP 3ph motor	1	V
I	Blower Stand	1	W
J	Outlet Foam Insulation (E)	1	X
K	Outlet Casting	1	Y
L	1/2" x 2 1/2" RD HD MS	4	Z
M	1/4" Lock Washers	4	AA
N	1/4"-20 x 1 3/4" Hx Bolts	8	BB
	1/4" Lock Washers	8	
	1/4" Hex Nuts	8	
	3/8" Lock Washers	4	
	3/8" Flat Washers	8	
	3/8" x 2 1/4" Hex Bolt	4	
	5/16" x 1" Hex Bolt	4	
	5/16" Flat Washers	8	
	5/16" Hex Nuts	4	
	3/8" Lock Washers	3	
	3/8" x 1" Hex Bolt	3	
	3/8" Flat Washers	3	
	5/16" Lock Washers	4	
	1/8" x 2" nipple	1	
	Dwyer Air Pres.Switch	1	

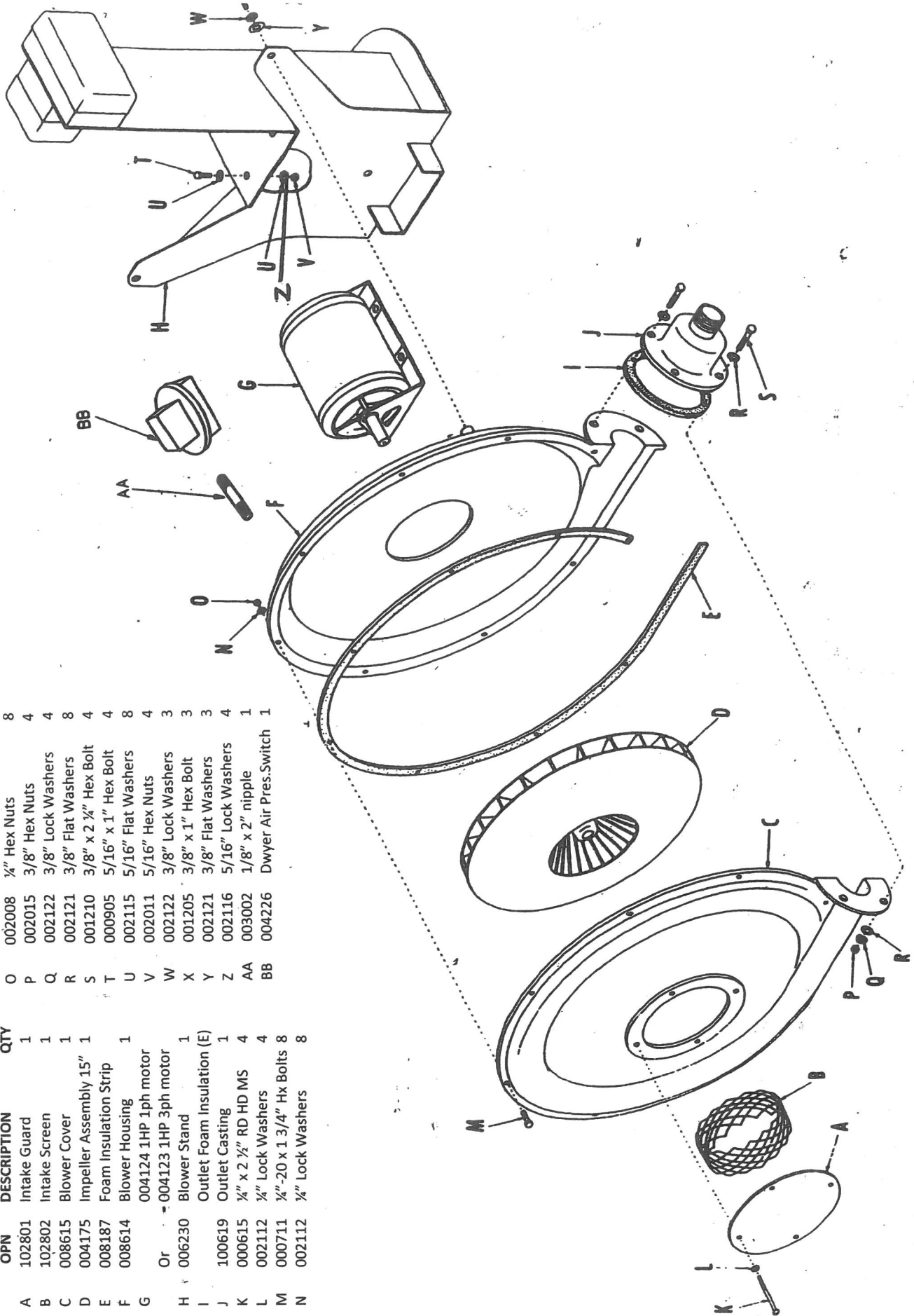

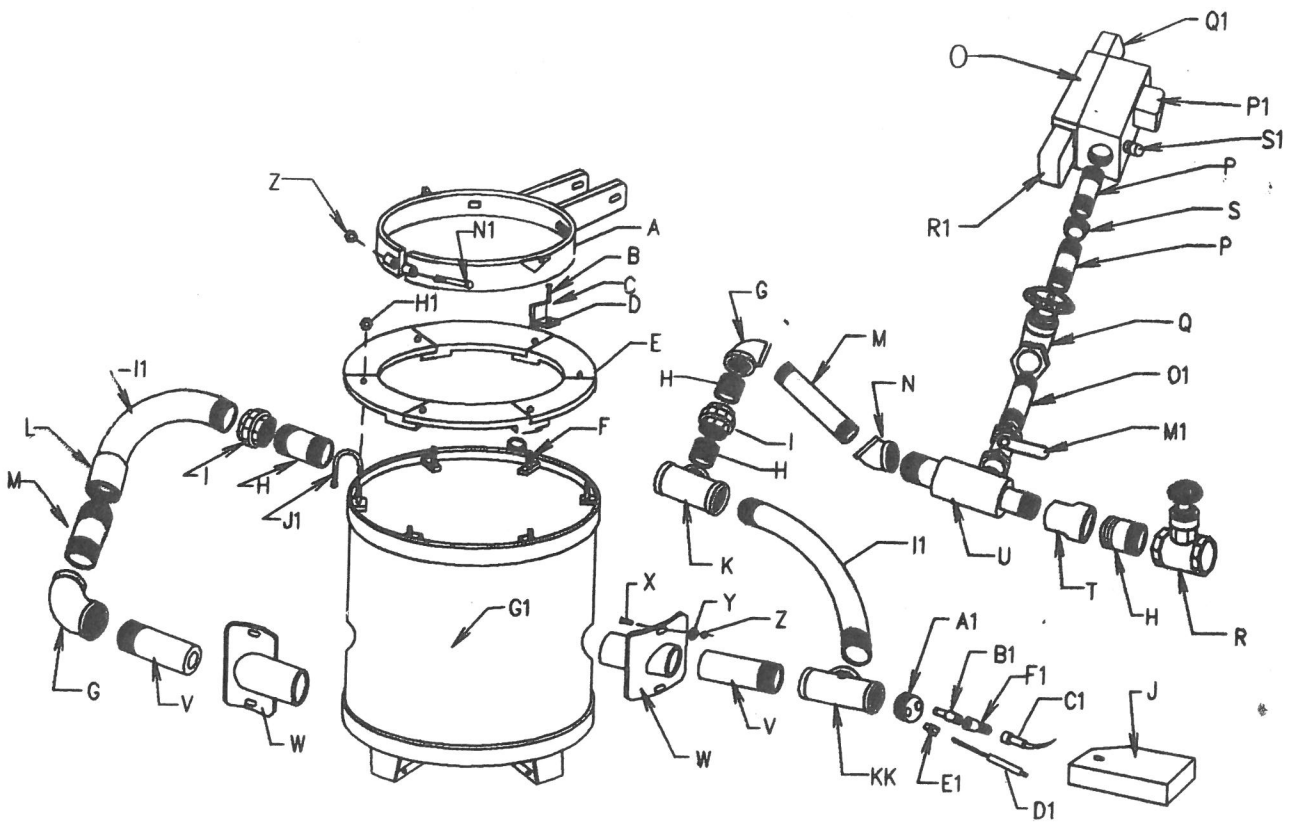

McEnglevan Parts List B-702 – revised 07/17/20

OPN	Description	Qty	OPN	Description	Qty
A	100875 Lid Band Assembly	1	W	100835 Burner Guide Tube	2
B	001205 3/8" x 1" Hex Hd Bolt	2	X	001304 3/8" x 1 1/2" Carriage Bolt	4
C	002122 3/8" lock washer	2	Y	002121 3/8" flat washer	4
D	100878 Lid Band Stop	1	Z	002015 3/8" hex nut	5
E	008603 Top Seal Segment	6	A1	006686 2" UV Plug	1
F	000911 5/16" x 2 1/4" Hx Bolt	6	B1	003024 1/2" x 3/8" swedged nipple	1
G	003379 2" 90 deg elbow	2	C1*	004107 6' UV Scanner	1
H	003141 2" x 2 1/2" nipple	4	D1	004068 7" Ignition Electrode	1
I	003370 2" Standard Union	2	E1	003408 1/2" x 3/8" Comp.Fitting	1
J	006690 UV Scanner Cover	1	F1	004097 Insulator	1
K	003311 2" Tee	1	G1	100815 Shell	1
L	003207 2" pipe coupling	1	H1	002012 5/16" jam nut	6
M	100876 2" x 11 3/4" nipple	2	I1	003390 2" Long Radius Elbow	2
N	003394 2" 45 deg elbow	1	J1	000987 3/8" x 2 1/2" U bolt	1
O**	003823 Dual Valve-Dungs# DMV-D 702/622 230-791P With proof of closure	1	M1	003455 1 1/4" ball valve (M1 on Canadian furnaces only)	1
P	003109 1 1/4" x 3" nipple	2	N1	001412 3/8-16 x 4 1/2" bolt	1
Q	003430 1 1/4" Gate Valve	1	O1	003113 1 1/4" x 6" nipple (O1 on Canadian furnaces only)	1
R	003432 2" Gate Valve	1	P1	Proof of closure switch (part of O)	1
S	003352 1 1/4" union	1	Q1	003816 Low gas pressure switch Dungs # GML-A2-4-4 266942	1
T	003224 2" x 1 1/2" red. coupling	1	R1	003780 High gas pressure switch Dungs #GMH-A2-4-4 266924	1
U	006070 GM-125 Gas/Air Mixer	1	S1	003836 Visual indicator Dungs# 217-665A	1
V	006610 2" Burner Nozzle	2			
KK	003309 UV tee assm	1			

*Pit installations require UV8A scanner and extra conduit/wire-call for correct item

** Models manufactured prior to 2015 have 004216 1 1/4" Gas Solenoid Valve

1912 (if 3 ph) or 1610 (if 1 ph) BLOWER ASSEMBLY FOR B-702 12/2018

OPN	DESCRIPTION	QTY	OPN	DESCRIPTION	QTY
A	102801 Intake Guard	1	W	002122 3/8" Lock Washers	3
B	102802 Intake Screen	1	X	001205 3/8"-16 x 1" Hex Bolt	3
C*	008609 1912 Blower Cover	1	Y	002121 3/8" Flat Washers	3
D*	004177 Impeller Assembly 21"	1	Z	002116 5/16" Lock Washers	4
E	008187 Foam Insulation Strip	1	A1	004226 Air pressure switch	1
F*	008610 1912 Blower Housing	1	B1	Dwyer 26-192281-00 2619	1
G	004129 2HP 1ph motor	1	C1	003600 1/8 x 2" nipple	1
Or	004132 2HP 3ph motor	1	D1	003624 Fuse Holder	1
Or	004180 208v 1ph motor	1	E1	003662 5 amp fuse	1
H	006230 Blower Stand	1	F1	003663 Start Switch	1
I	Outlet Foam Insulation (E)	1	G1	003663 Stop Switch	1
J*	400501 1912 Outlet Casting	1	H1	004445 Fireye Chassis	1
K	000615 1/4" x 2 1/2" gr 5 bolt	4	I1	003906 Red light	1
L	002112 1/4" Lock Washers	12	J1	004105 Fireye Sub-base	1
M	000711 1/4"-20 x 1 3/4" Hx Bolts	8	K1	003852 8x10 box	1
N	004300 Ignition Transformer	1		003914 Stepdown transformer	1
	10000v			(if not 110v or 208v)	
O	002008 1/4" Hex Nuts	8			
P	002015 3/8" Hex Nuts	4			
Q	002122 3/8" Lock Washers	4			
R	002121 3/8" Flat Washers	8			
S	001210 3/8" x 2 1/2" Hex Bolt	4			
T	000905 5/16" x 1" Hex Bolt	4			
U	002115 5/16" Flat Washers	8			
V	002011 5/16" Hex Nuts	4			
* As of 11/01/12 1 phase furnaces use					
004176	18" alum impeller	1			
	#1610 blower assm	1			

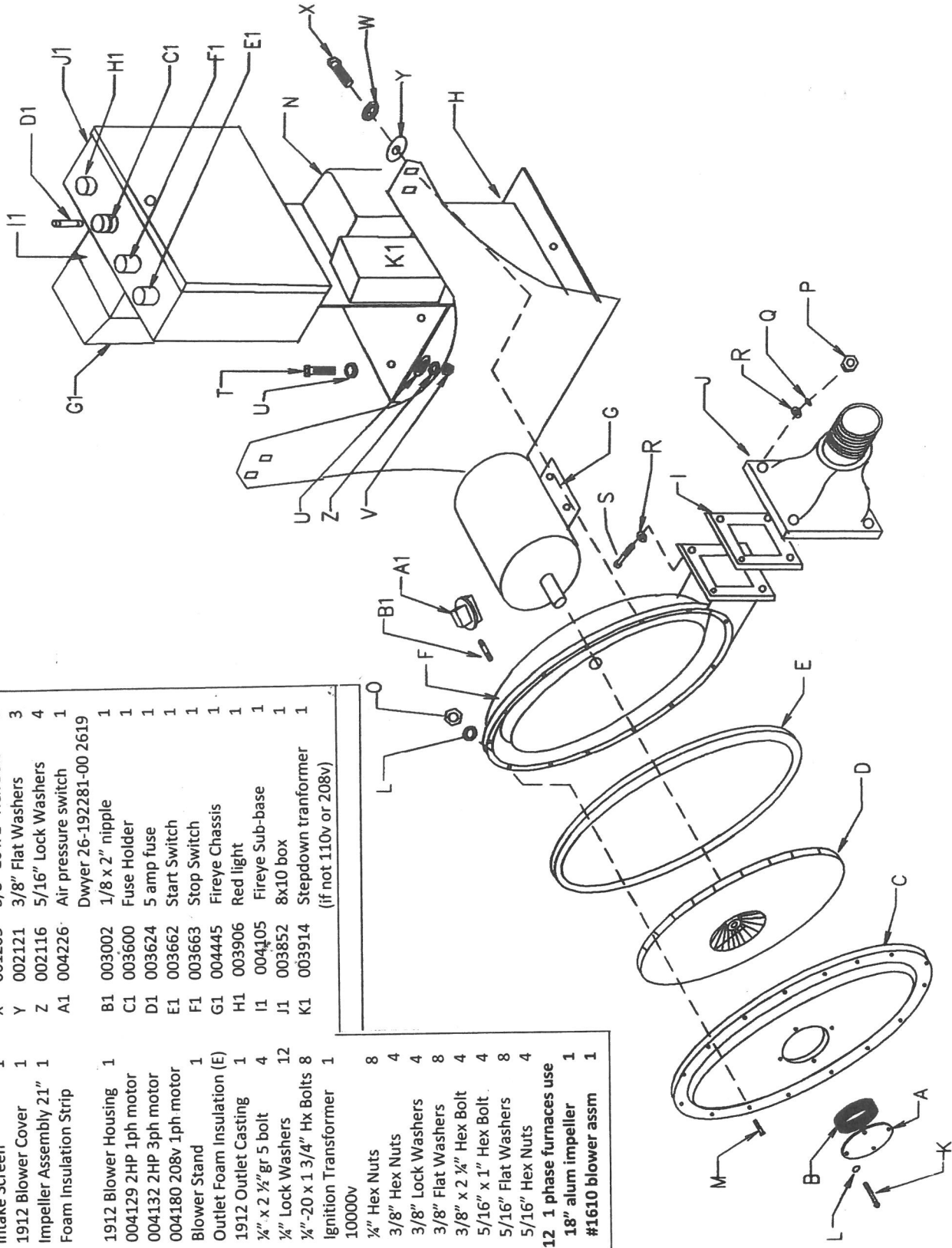

B1501 See parts listing on the following page

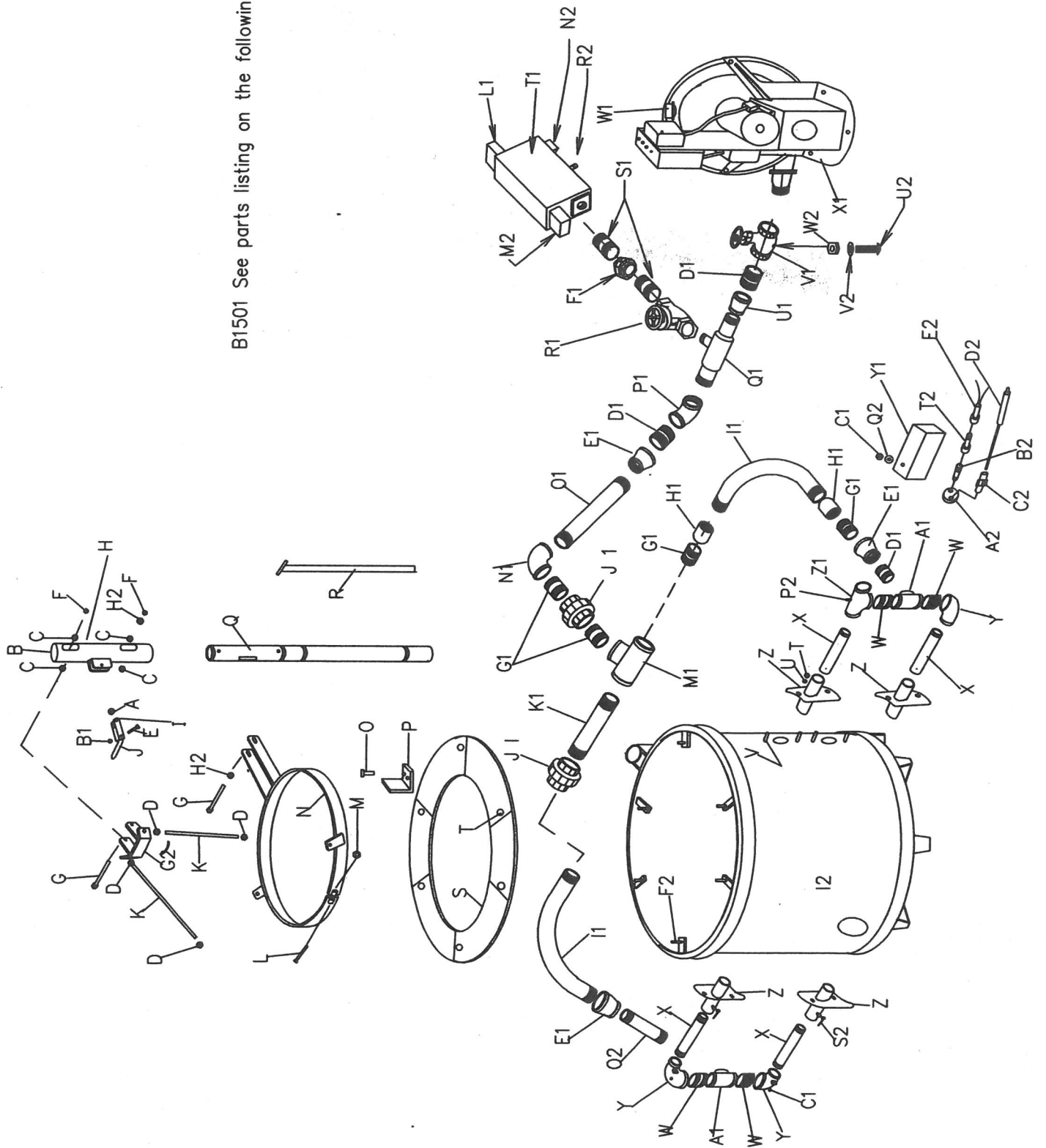

McEnglevan B1501 Parts Listing

revised 12/28/22

Part #	Description	Qty	Part #	Description	Qty
A	002473 Radial Bearing	1	N1	003407 2 1/2" 90 deg Elbow	1
B	101081 Swivel Pipe	1	O1	003168 2 1/2" x 8" Nipple	1
C	002467 Sealed Bearing	4	P1	003394 2" 45 deg Elbow	1
D	002023 1/2" Jam Nut	8	Q1	006070 GM-125 Gas/Air Mixer	1
E	001208 3/8" x 1 3/4" Hex Hd Bolt	1	R1	003430 1 1/4" Gate Valve	1
F	002024 1/2" Hex Lock Nut	2	S1	003109 1 1/4" x 3" Nipple	2
G	001518 1/2" x 5 1/2" Hex Hd Bolt	2	T1	003823 Dual Valve With Proof Of Closure KDI#267016 DMV-D 702/622	1
H	010005 Drive In Grease Fitting	2	U1	003224 2" x 1 1/2" Reducing Cpling	1
I	002423 Fulcrum Spring Pin	1	V1	003432 2" Gate Valve	1
J	101075 Fulcrum Handle	1	W1	004226 Air Pressure Switch	1
K	101063 Support Rod	2	X1	900515 Blower Assembly #1912	1
L	001215 3/8 x 3 1/2" Hex Hd Bolt	1	Y1	101153 UV Scanner Cover	1
M	002015 3/8" Hex Nut	9	Z1	003293 1 1/2" x 1 1/2" x 2" UV Tee	1
N	101064 Lid Band	1	A2	006665 1 1/2" UV Plug	1
O	001205 3/8" x 1" Hex Hd Bolt	2	B2	003024 1/2" x 3/8" Reducing Nipple	1
P	101052 Lid Band Stop	1	C2	003408 1/2" x 3/8" Comp.Fitting	1
Q	101095 Jack Tube	1	D2	004068 7" Ignition Electrode	1
R	010068 Lid Lift Handle	1	E2	004109 UV8A Scanner	1
S	101070 Top Seal Segment	6	F2	001209 3/8" x 2" Hex Head Bolt	6
T	002015 3/8" Nut	6	G2	101090 Support Rod Bracket	1
U	002121 3/8" Flat Washer	8	H2	002131 1/2" Flat Washer	1
V	001305 3/8" x 1" Carriage Bolt	8	I2	101031 Steel Shell Assembly	1
W	003159 2" Butt Nipple	4	M2	003780 High Pressure Gas Switch KDI#GMH-A2-4-4	1
X	006611 Burner Nozzle	4	N2	Proof of Closure Switch (Part of T1)	1
Y	003385 1 1/2" x 2" Elbow	3	O2	003148 2" x 6" Nipple	1
Z	101035 Burner Guide Tube	4	P2	000606 1/4 -20 x 3/4" PPH mach screw	1
A1	003311 2" Tee	2	Q2	002111 1/4" Flat Washer	1
B1	002017 3/8" Lock Nut	1	R2	003836 Visual Indicator	1
C1	002008 1/4" Hex Nut	5	S2	002360 Eyebolt	4
D1	003141 2" x 2 1/2" Nipple	3	T2	004097 Extender	1
E1	003230 2 1/2" x 2" Reducing Coupling	1	U2	000709 1/4-20 x 1 1/4" capscrew	1
F1	003352 1 1/4" Union	1	V2	002112 1/4" lock washer	1
G1	003166 2 1/2" x 3" Nipple	4	W2	002008 1/4-20 nut	1
H1	003208 2 1/2" Coupling	1			
I1	003795 2 1/2" Lg Radius Elbow	2			
J1	003368 2 1/2" Standard Union	2			
K1	101157 2 1/2" x approx. 6" Nipple	1			
L1	003816 Low Gas Pressure Switch KDI#GML-A2-4-4	1			
M1	003118 2 1/2" Tee	1			

1912 BLOWER ASSEMBLY FOR B-1501 and B-2001 12/2018

OPN	DESCRIPTION	QTY	OPN	DESCRIPTION	QTY
A	Intake Guard	1	W	3/8" Lock Washers	3
B	Intake Screen	1	X	3/8"-16 x 1" Hex Bolt	3
C	Blower Cover	1	Y	3/8" Flat Washers	3
D	Impeller Assembly 21"	1	Z	5/16" Lock Washers	4
E	Foam Insulation Strip	1	A1	Air pressure switch	1
F	Blower Housing	1	B1	1/8 x 2" nipple	1
G	004129 2HP 1ph motor	1	C1	Fuse Holder	1
Or	004132 2HP 3ph motor	1	D1	5 amp fuse	1
H	Blower Stand	1	E1	Start Switch	1
I	Outlet Foam Insulation (E)	1	F1	Stop Switch	1
J	Outlet Casting	1	G1	Fireye Chassis	1
K	1/4" x 2 1/2" RD HD MS	4	H1	Red light	1
L	1/4" Lock Washers	12	I1	Fireye Sub-base	1
M	1/4"-20 x 1 3/4" Hx Bolts	8	J1	8x10 box	1
N	Ignition Transformer	1			
O	1/2" Hex Nuts	12			
P	3/8" Hex Nuts	4			
Q	3/8" Lock Washers	4			
R	3/8" Flat Washers	8			
S	3/8" x 2 1/4" Hex Bolt	4			
T	000905 5/16" x 1" Hex Bolt	4			
U	002115 5/16" Flat Washers	8			
V	002011 5/16" Hex Nuts	4			

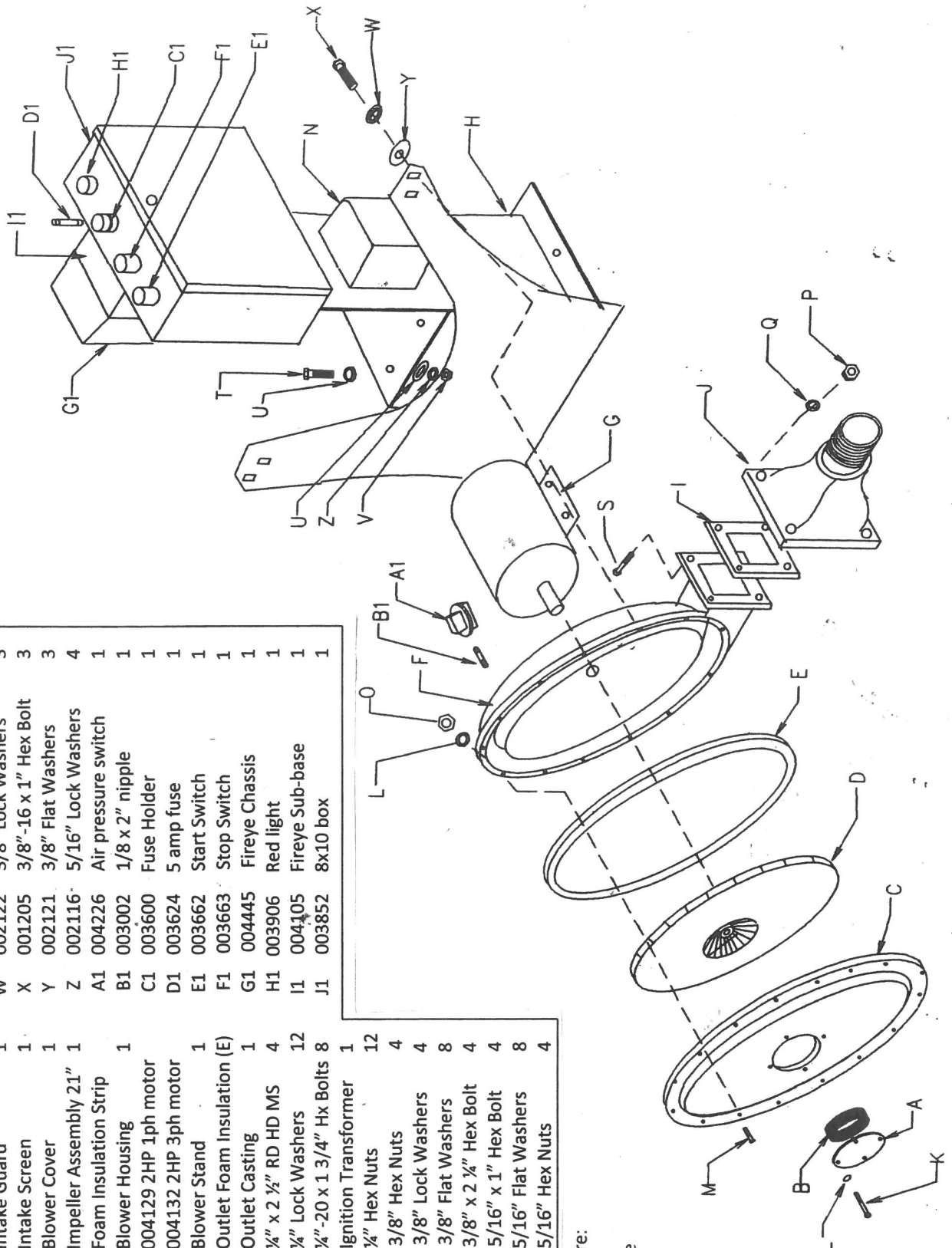

1/2013 Single phase furnaces require:

- D 004177-1/8" Impeller 1 1/8" bore
- G 004161 Motor 3HP
- H 006230SP Blower stand
- J1 003788 Enclosure 12x10x6

B2001 See parts listing on the following page

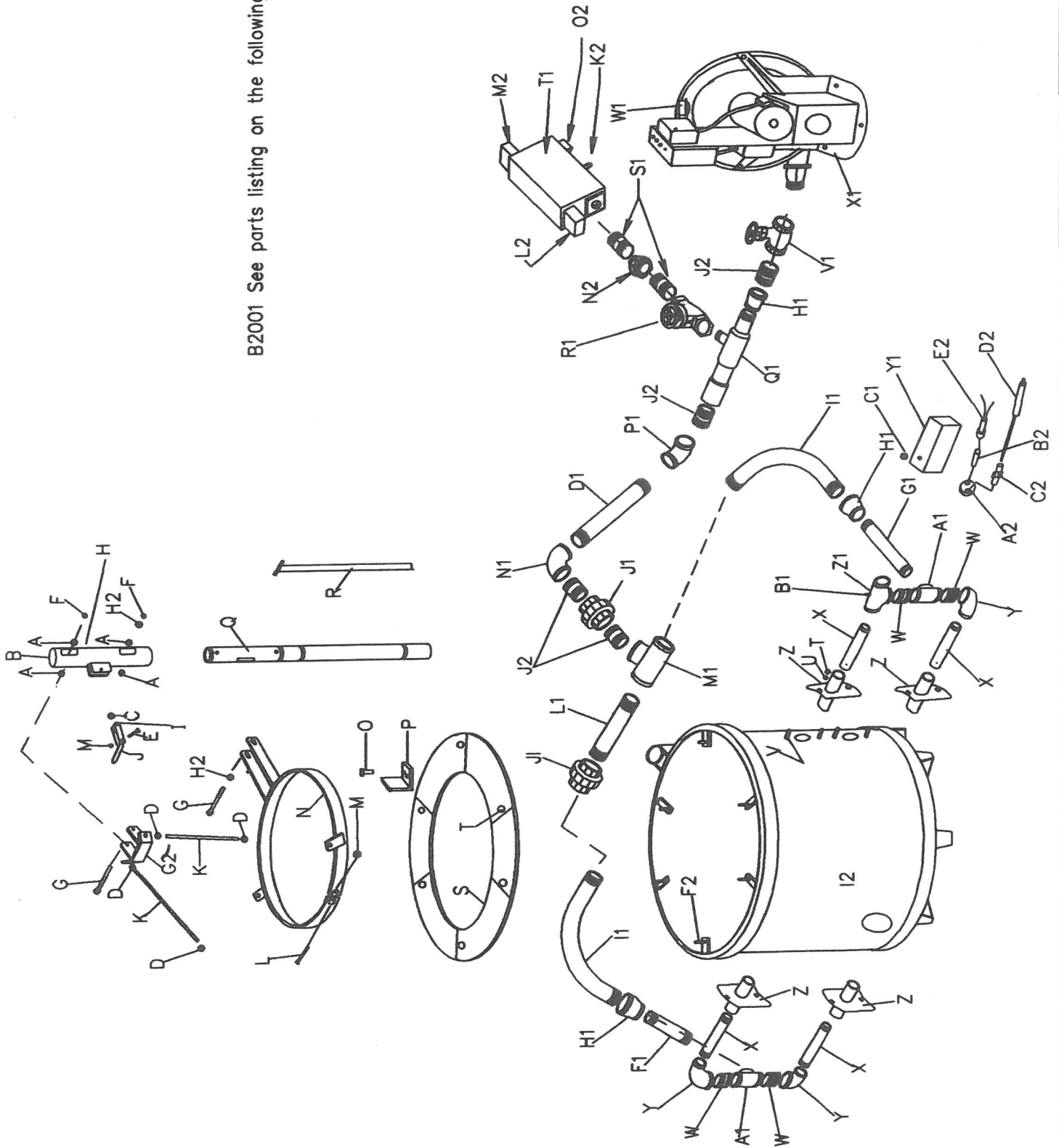

B2001 Std Model Parts Listing 10/2023

A	002473 Radial bearing	4	I1	003795 2 1/2" lg radius elbow	2
B	101081 Swivel pipe	1	J1	003368 2 1/2" standard union	2
C	002467 Sealed bearing	1	L1	103254 2 1/2" x 11" nipple	1
D	002023 1/2" jam nut	8	M1	003118 2 1/2" tee	1
E	001208 3/8 x 1 3/4" hex bolt	1	N1	003407 2 1/2" 90 deg elbow	1
F	002024 1/2" hex lock nut	2	P1	003396 2 1/2" 45 deg elbow	1
G	001518 1/2" x 5 1/2" hex bolt	2	Q1	006080 GM150 mixer	1
H	010005 Grease fitting	2	R1	003430 1 1/4" gate valve	1
I	002423 Fulcrum spring pin	1	S1	003109 1 1/4" x 3" nipple	2
J	101087 Hand Fulcrum	1	T1	* 003823 Dual valve with proof of	1
K	102586 Support rods	2		closure KDI# DMV-D 702/622 230-79	
L	001215 3/8" x 3 1/2" hex bolt	1	V1	003434 2 1/2" gate valve	1
M	002015 3/8" hex nut	10	W1	004226 Air pressure switch	1
N	102581 Lid band	1	X1	400429 Blower assm #1912	1
O	001205 3/8" x 1" hex bolt	2	Y1	101153 UV scanner cover	1
P	101052 Lid Band Stop	1	Z1	003293 1 1/2" x 1 1/2" x 2" tee	1
Q	101095 Jack tube	1	A2	006665 1 1/2" UV plug	1
R	010068 Lid lift handle	1	B2	003024 1/2" x 3/8" reducing nipple	1
S	103211 Top seal segment	6	C2	003408 1/2" x 3/8" comp.fitting	1
T	002016 3/8" Jam nut	6	D2	004068 7" electrode	1
U	002121 3/8" flat washer	8	E2	004109 UV8A scanner	1
V	001304 3/8" x 1 1/4" carr.bolt	8	F2	001209 3/8" x 2" hex bolt	6
W	003159 2" butt nipple	4	G2	101090 Support rod bracket	1
X	006611 8 1/2" burner nozzle	4	H2	002131 1/2" flat washer	5
Y	003385 1 1/2" x 2" 90 deg elb	3	I2	Steel shell assembly	1
Z	102550 Burner guide tube	4	J2	003120 2 1/2" close nipple	3
A1	003311 2" tee	2	K2	003836 Visual indicator	1
B1	000606 1/4 x 3/4 RD HD MS	4	L2	003780 High pressure gas switch	1
C1	002008 1/4" hex nut	5		KDI#GMH-A2-4-4, 266924	
D1	103253 2 1/2" x 16" nipple	1	M2	003816 Low pressure gas switch	1
F1	103252 2" x 8 1/4" nipple	1		KDI# GML-A2-4-4, 266942	
G1	103255 2" x 12" nipple	1	N2	003352 1 1/4" union	1
H1	003230 2 1/2" x 2" red.coupling	3	O2	Proof of closure switch (part of T1)	1

**004216 1 1/4" solenoid valve on units
prior to year 2015

UV Combustion Safeguard With Fire Eye MEC 120

With Proof Of Closure

120V 1Ph 60Hz

Customer to supply dedicated ground line, plus surge & fuse protection,

Equipment Grounding Green

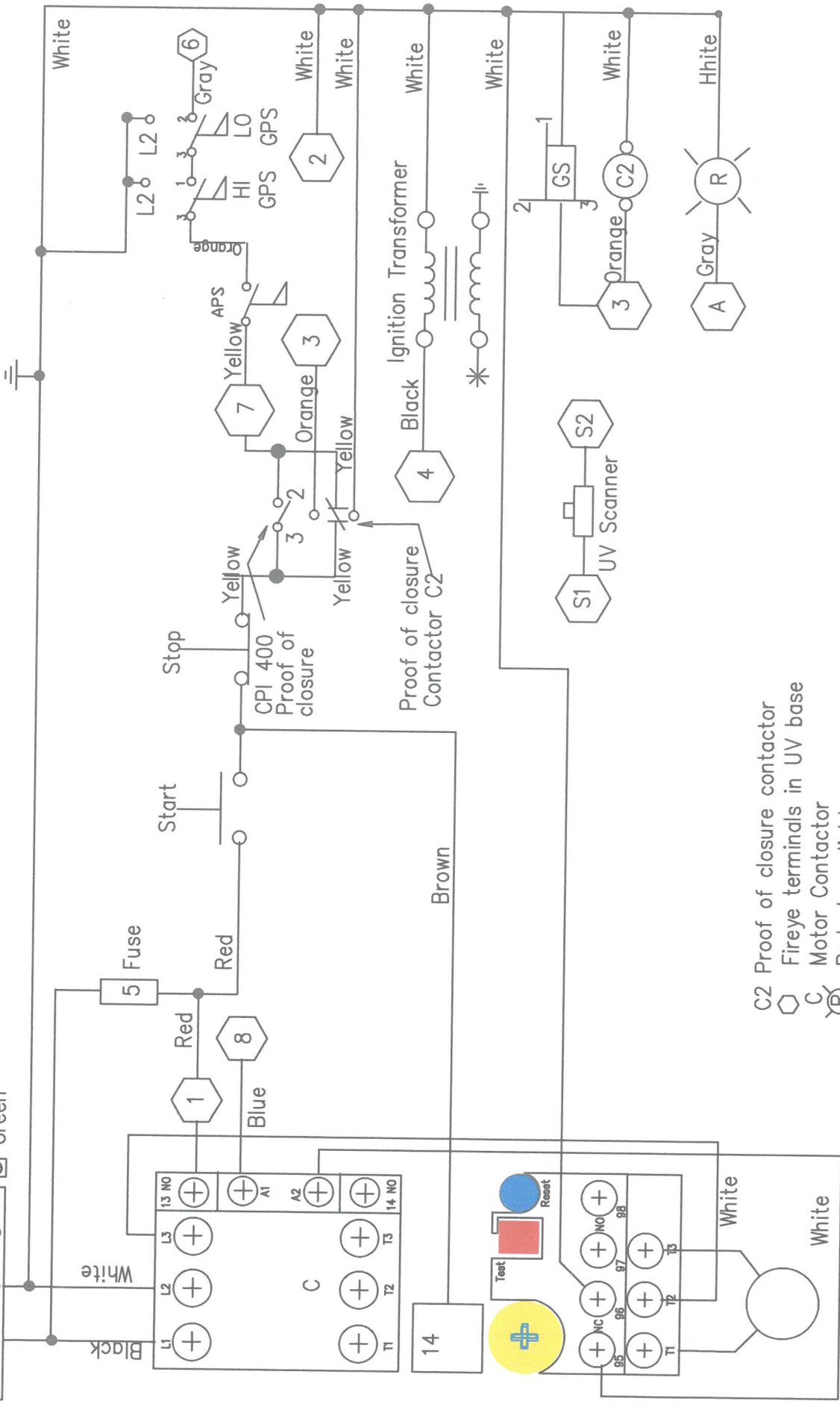

- C2 Proof of closure contactor
- Fireye terminals in UV base
- C Motor Contactor
- Red alarm light
- Dual multi valve 2/3
- Air pressure switch

WD-0049

Drawn By Bill Walter

4 UV Combustion Safe Guard With Proof Of Closure
120 V 1 ph-60 Hz

MIFCO

9/23/21

230V 1Ph 60Hz

UV Combustion Safeguard With Fire Eye MEC 120

With Proof Of Closure

Equipment Grounding

Customer to supply dedicated ground line, plus surge & fuse protection,

230 V

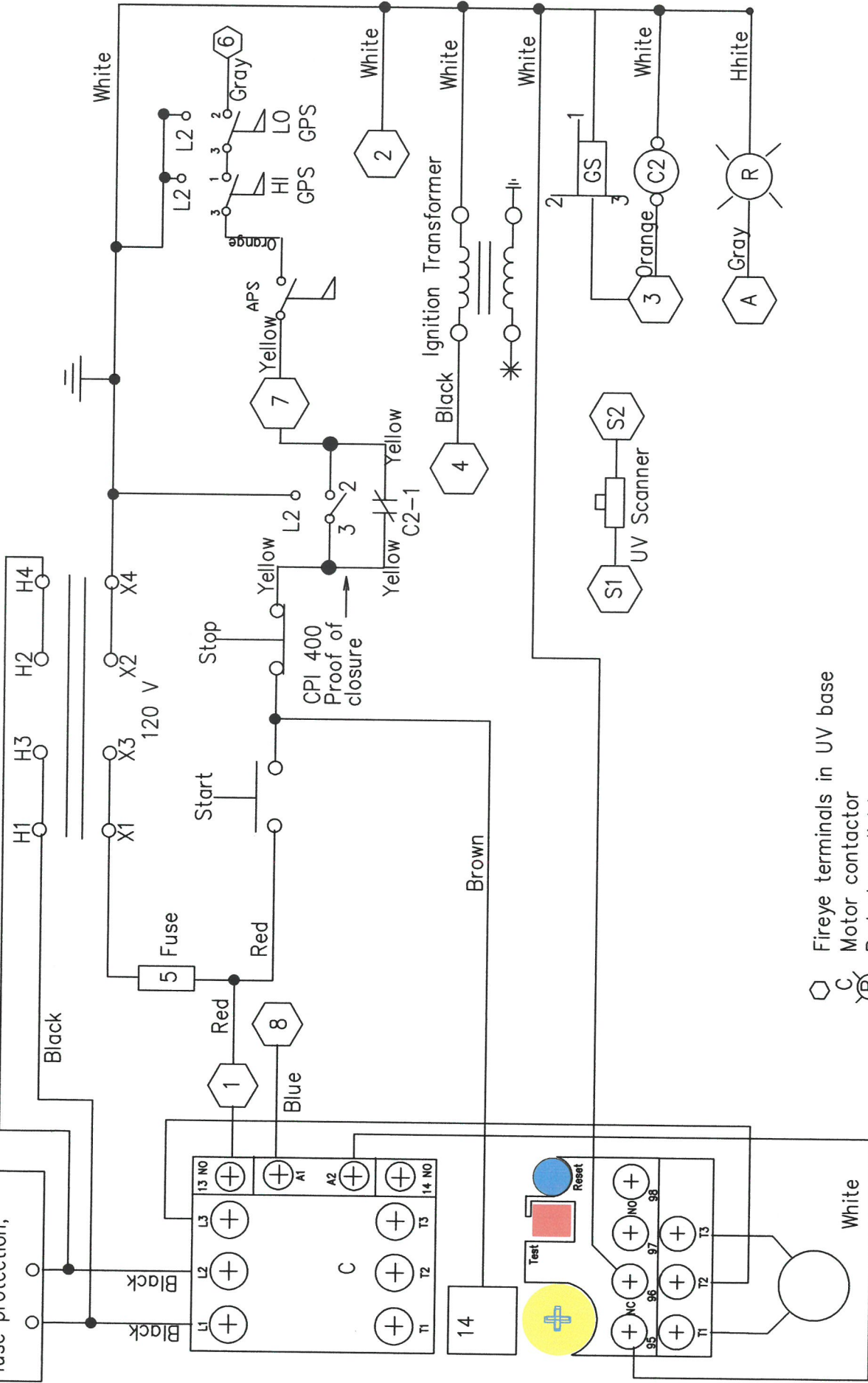

- Fire eye terminals in UV base
- Motor contactor
- Red alarm light
- Dual multi valve 2 3 1
- AFS Air pressure switch

WD-0046

Drawn By Bill Walter
 4 UV Combustion Safe Guard With Proof Of Closure
 230 V 1 ph-60 Hz

MIFCO

1/21/15

230 V-3Ph-60 Hz

UV Combustion Safeguard With Fire Eye MEC 120

With Proof Of Closure

Customer to supply dedicated ground line, plus surge & fuse protection,

230 V

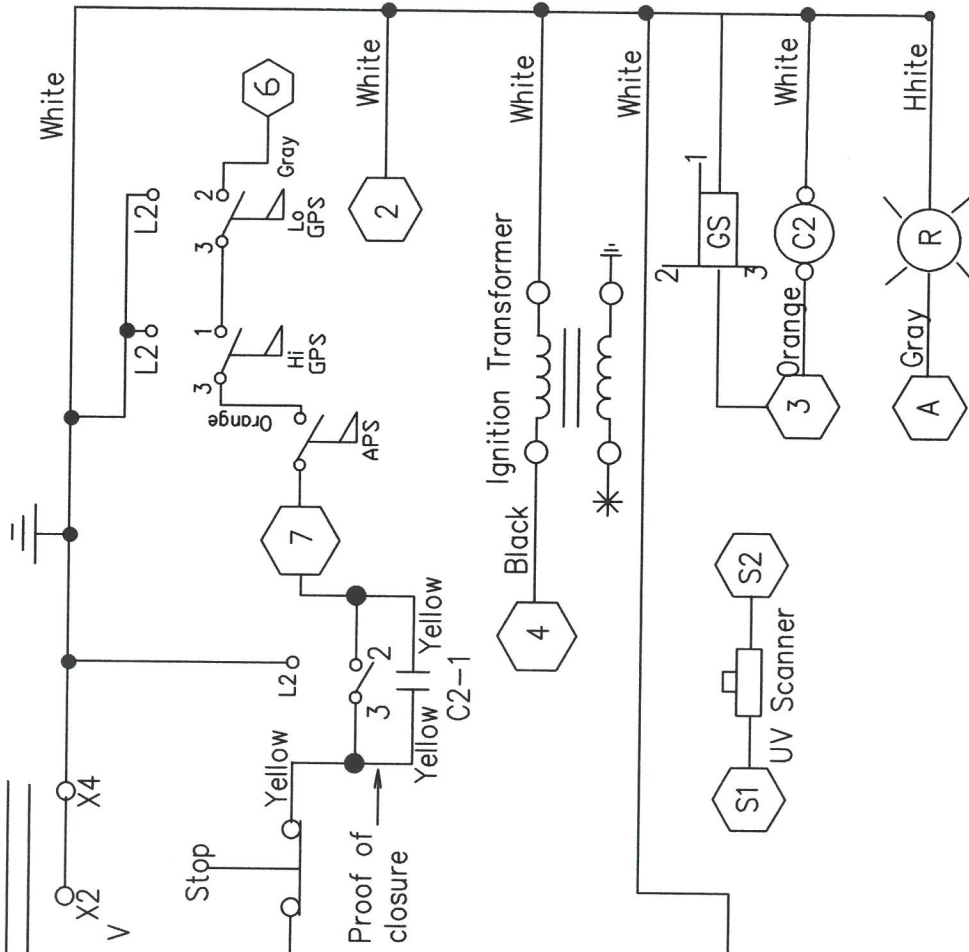
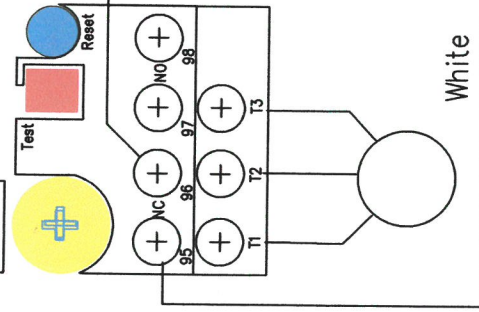
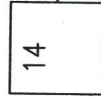
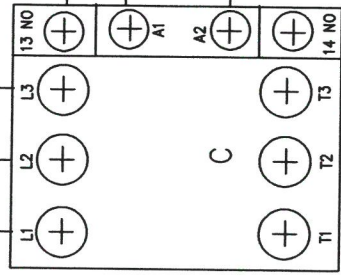
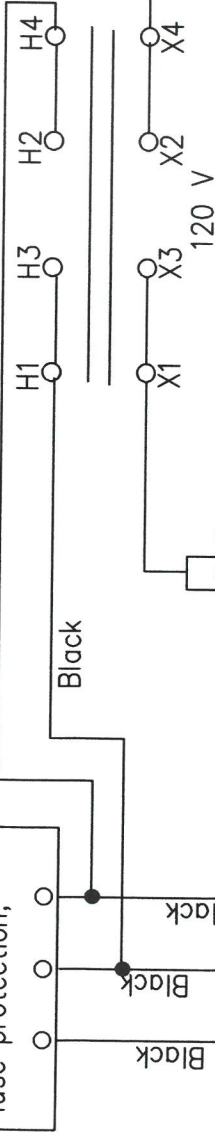

- Fireye terminals in UV base
- Motor Contactor
- Red alarm light
- Dual multi valve
- AFS Air pressure switch

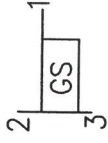

WD-0045

Drawn By Bill Walter
 4 UV Combustion Safe Guard With Proof Of Closure
 230 V 3 ph-60 Hz
 MIFCO
 1/21/15

UV Combustion Safeguard With Fire Eye MEC 120

With Proof Of Closure

460V-3Ph-60 Hz

Customer to supply dedicated ground line, plus surge & fuse protection,

Equipment Grounding
 ○ — Green
 — Black

460V

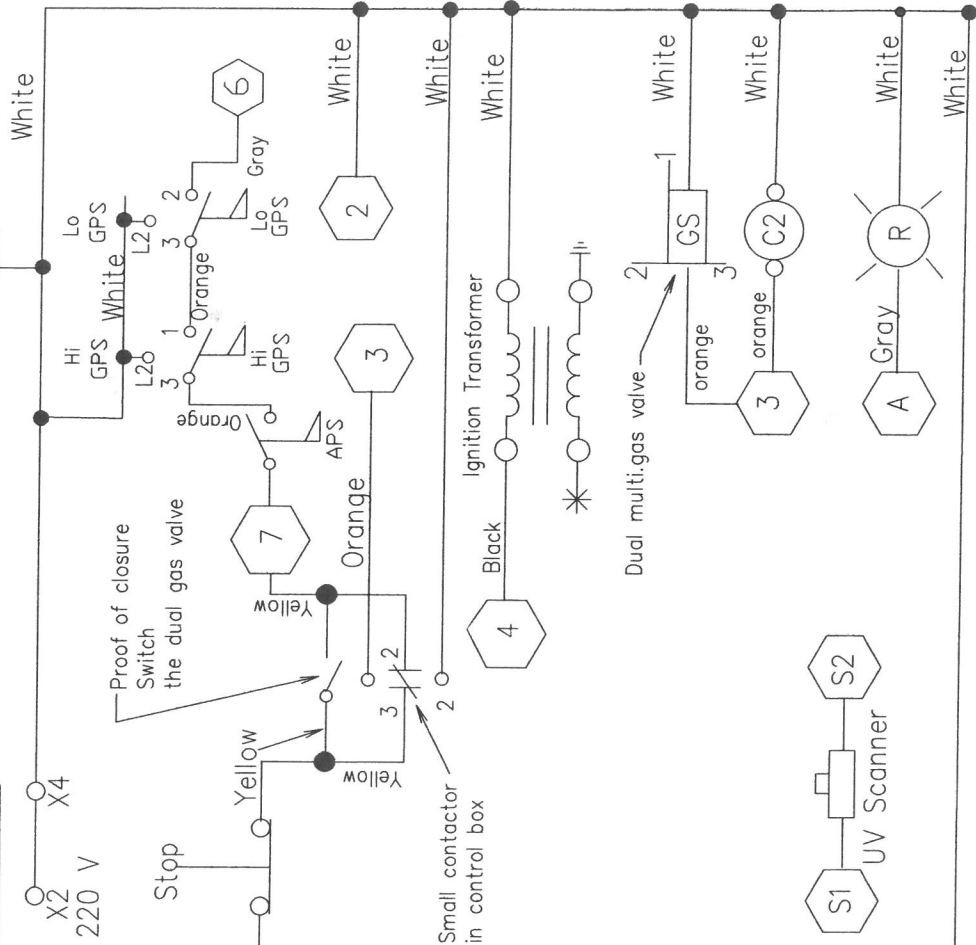
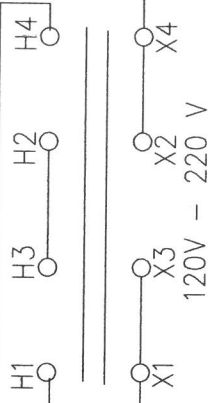

Proof of closure Switch the dual gas valve

Small contactor in control box

Dual multi.gas valve

- C2 Proof of closure contactor
- Fireye terminals in UV base
- C2 Motor contactor
- (R) Red alarm light
- GS Dual multi valve
- AFS Air pressure switch

WD-0048

Drawn By Bill Walter
 4 UV Combustion Safe Guard With Proof Of Closure
 460 V 3 ph-60 Hz

MIFCO

1/20/22

208 V 1Ph-60 Hz

UV Combustion Safeguard With Fire Eye MEC 120

With Proof Of Closure

Customer to supply dedicated ground line, plus surge & fuse protection,

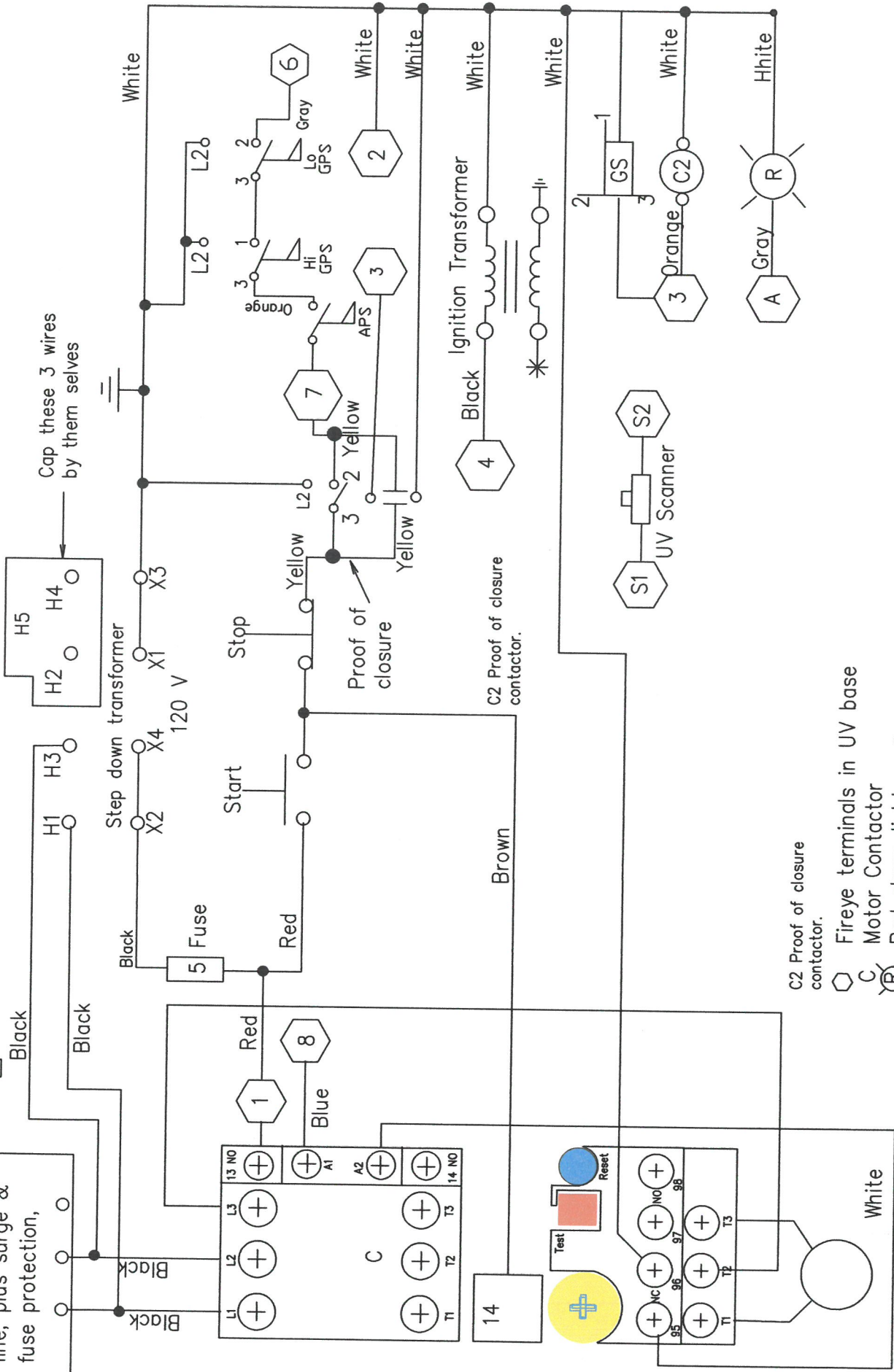

Cap these 3 wires by them selves

- C2 Proof of closure contactor.
- Fireeye terminals in UV base
- C Motor Contactor
- Red alarm light
- Dual multi valve
- AFS Air pressure switch

WD-0053

Drawn By Bill Waiter

4 UV Combustion Safe Guard With Proof Of Closure
 208 V 1 ph-60 Hz

MIFCO

12/22/22